



Radio / CD / MP3

Bremen MP74 US

7 644 821 310

Operating instructions



<http://www.blaupunkt.com>

 **BLAUPUNKT**

Caution:

The device's tuner is already configured at the factory for the North/South America region ("AREA USA"). If you are outside North/South America, please select the "AREA EUR" setting. For further details, please read the section entitled "Adjusting the tuner settings" in the "Radio mode" chapter.

Attention :

Le récepteur de l'autoradio est réglé par défaut sur la région Amérique du Nord / Amérique latine (« AREA USA »). Quand vous vous trouvez en dehors de l'Amérique du nord ou de l'Amérique latine, sélectionnez l'option « AREA EUR ». Pour plus d'informations, reportez-vous à la section « Réglage du tuner » du chapitre « Mode RADIO ».

Atención:

El sintonizador del equipo sale de fábrica programado para la región de Norteamérica / Sudamérica ("AREA USA"). Si se encuentra fuera de la región de Norteamérica / Sudamérica, seleccione la opción "AREA EUR". Para más detalles, lea el punto "Ajustar el sintonizador" en el capítulo "Modo de radio".



Atenção:

O receptor do aparelho foi originalmente configurado para uso na região da América do Norte e Sul ("AREA USA"). Quando abandonar a área da América do Norte/Sul, escolha a configuração "AREA EUR". Para tal, leia o parágrafo "Configurar o sintonizador" no capítulo "Rádio".

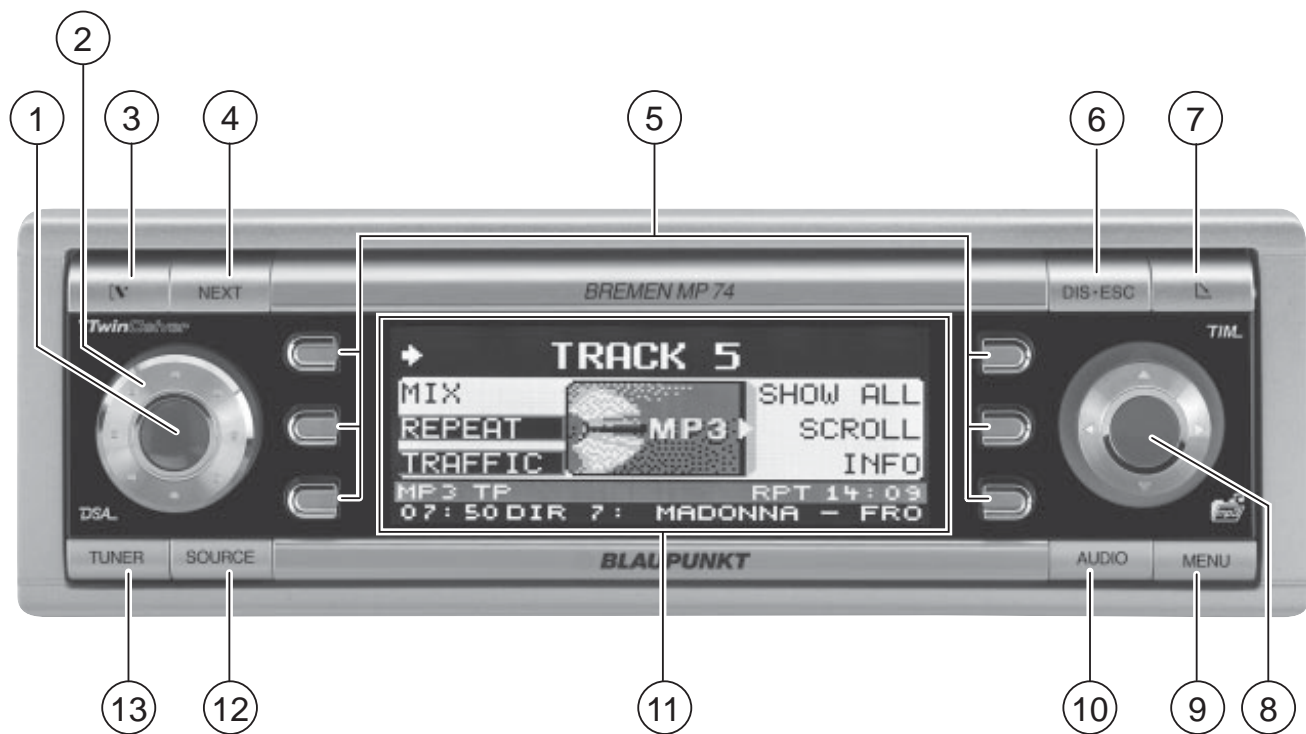
Open here
Ouvrir s.v.p.
Por favor, abrir
Favor abrir



CONTROLS

- ① Button, to switch the device on/off, and mute the device's volume
- ② Volume control
- ③  button, to unlatch the detachable control panel
- ④ **NEXT** button to display the next pages of a menu, and switch memory banks in radio mode
- ⑤ Softkeys, the function of the softkeys depends on what is currently being displayed
- ⑥ **DIS•ESC** button to change the display content and close menus
- ⑦  button to open the detachable control panel (flip-release panel)
- ⑧ Joystick and **OK** button
- ⑨ **MENU** button to open the basic settings menu (short press)
Activate/deactivate demo mode (long press)
- ⑩ **AUDIO** button to adjust the bass, treble, balance, fader and X-BASS (short press)
Access the DSA Max Equalizer (Long press)
- ⑪ Display
- ⑫ **SOURCE** button to start CD / CD-changer playback, start playing the Compact Drive MP3 (only if connected)
or
To play an external audio source (only if connected)
- ⑬ **TUNER** button to select radio mode directly
To access the radio functions menu (only possible in radio mode)

Notes and accessories	7	Radio mode	17
Road safety	7	Adjusting the tuner settings	17
Safety notice	7	Setting the number of antennas	18
Installation	7	Switching to radio mode	18
Accessories	8	Selecting static/dynamic radio mode (only FM)	18
Activating / deactivating demo mode	8	RDS function	20
Theft protection	9	Selecting the waveband / memory bank	20
Detachable control panel	9	Tuning into a station	21
Detaching the control panel	9	Setting the sensitivity of station seek tuning	21
Attaching the control panel	9	Scanning receivable stations (SCAN)	21
Switching on/off	10	Setting the scanning time	22
Adjusting the volume	10	Storing stations	22
Setting the power-on volume	10	Storing stations automatically (Travelstore)	22
Volume mute	11	Listening to stored stations	22
Telephone audio	11	Programme type (PTY)	23
Navigation audio	11	Optimising radio reception	24
Sound and volume distribution settings	13	Activating/deactivating the radio text display	24
Adjusting the bass	13	CD mode	25
Adjusting the treble	13	Switching to CD mode and inserting a CD	25
Adjusting the right/left volume distribution (balance)	13	Ejecting a CD	25
Adjusting the front/back volume distribution (fader)	13	Selecting tracks	25
X-BASS	14	Fast searching (audible)	26
Adjusting the display settings	14	Random track play (MIX)	26
Adjusting the viewing angle	14	Repeating tracks (REPEAT)	26
Adjusting the display brightness	14	Scanning tracks (SCAN)	26
Setting the button illumination colour	15	Displaying CD text	26
Setting the display illumination colour	15	Setting scrolling text	27
Configuring the spectrum analyser	16		
Inverting the appearance of the display content	17		

CONTENTS

MP3 mode	27	Selecting sound presets	40
Preparing an MP3-CD	27	Setting the stage effect	40
Switching to MP3 mode	28	Selecting the sound effect	41
Selecting a directory	29	DNC -	
Selecting tracks	29	Dynamic Noise Covering	41
Fast searching (audible)	30	Calibrating DNC	41
Scanning tracks (SCAN)	30	Switching off DNC	42
Random track play (MIX)	30	Selecting the DNC boost	42
Repeating individual tracks or whole directories (REPEAT)	30	Subwoofer and centre	
Configuring the display	31	speaker	43
CD-changer mode (optional) .	32	Adjusting the subwoofer boost level (gain)	43
Switching to CD-changer mode	32	Adjusting the subwoofer phase	43
Selecting CDs	32	Setting up the low-pass filter	43
Selecting tracks	32	Setting up the subsonic filter	44
Fast searching (audible)	32	Setting up the centre speaker	44
Scanning tracks (SCAN)	33	Setting up the high-pass filter for the front/rear channels	45
Repeating individual tracks or whole CDs (REPEAT)	33	Amplifier/sub-out	46
Random track play (MIX)	33	Switching the internal amplifier on/off	46
Naming CDs	34	External audio sources	46
CLOCK time	35	Switching the AUX input on/off	46
Setting the clock time	35	Naming the AUX input	47
Displaying the clock time continuously	36	Entering the power-on	
DSA Max -		message	48
Digital Sound Adjustment	36	Displaying the serial number .	48
Switching DSA on/off	36	Resetting the device	49
Automatically calibrating the equalizer	37	Specifications	49
Viewing the vehicle acoustics with/ without equalization	38	Installation instructions	194
Adjusting the graphic equalizer manually	38		
Selecting an equalizer	39		
Resetting the equalizer	39		

Notes and accessories

Thank you for choosing a Blaupunkt product. We hope you enjoy using this new piece of equipment.

Please read these operating instructions before using the equipment for the first time.

The Blaupunkt editors are constantly working on making the operating instructions clearer and easier to understand. However, if you still have any questions on how to operate the device, please contact your dealer or the telephone hotline for your country. You will find the telephone number printed at the back of this booklet.

We provide a manufacturer guarantee for our products bought within the European Union. You can view the guarantee conditions at www.blaupunkt.de or ask for them directly at:

Blaupunkt GmbH
Hotline
Robert Bosch Str. 200
31139 Hildesheim
Germany

Road safety

 Road safety has absolute priority. Only operate your car sound system if the road and traffic conditions allow you to do so. Familiarise yourself with the device before setting off on your journey.

You should always be able to hear police, fire and ambulance sirens in good time from inside your vehicle. For this reason, listen to your car sound system at a suitable volume level during your journey.

Safety notice

 The car sound system and the device's control panel (flip-release panel) heat up during use.

Therefore, when removing the flip-release panel, only hold it by its non-metallic surfaces. Allow the car sound system to cool down first if you want to uninstall the whole unit.

Installation

If you want to install your car sound system yourself, please read the installation and connection instructions that follow these operating instructions.

NOTES AND ACCESSORIES

Accessories

Only use accessories approved by Blaupunkt.

Remote control

The RC 08, RC 10 or RC 10H remote controls (available as optional accessories) allow you to access most of the main functions of your car sound system safely and conveniently.

You cannot switch the device on/off using the remote control.

Amplifiers

You can use all Blaupunkt and Velocity amplifiers.

CD changers

You can obtain the following CD changers from accessory retailers for connection to this device: CDC A 03, CDC A 08 and IDC A 09.

Compact Drive MP3

You can connect the Compact Drive MP3 instead of a CD-changer in order to play MP3 music tracks. If you decide to connect a Compact Drive MP3, you will first need to use a computer to store the MP3 music tracks on the Microdrive™ hard disk that is inside the Compact Drive MP3. Then, when the Compact Drive MP3 is connected to the car sound system, you can play the tracks like normal CD music tracks.

The Compact Drive MP3 is operated in a similar way to a CD-changer. Most of the CD-changer functions can also be used with the Compact Drive MP3.

Activating / deactivating demo mode

The device is supplied from the factory with demo mode activated. The various functions of the device are displayed graphically as animations in the display during demo mode. You can also deactivate demo mode.

- ⇒ Press and hold down the **MENU** button (9) for longer than four seconds to activate/deactivate demo mode.

Theft protection

Detachable control panel

Your device is equipped with a detachable control panel (flip-release panel) as a theft protection measure.

The device is worthless to a thief without this control panel. Protect your device against theft by taking the control panel with you whenever you leave your vehicle. Do not leave the control panel inside your vehicle - not even in a hiding place. The control panel has been designed to be easy to use.

Note:

- Never drop the control panel.
- Never expose the control panel to direct sunlight or other heat sources.
- Store the control panel in the supplied case.
- Avoid direct skin contact with the control panel's electrical contacts. If necessary, clean the contacts with a lint-free cloth and some alcohol.

Detaching the control panel

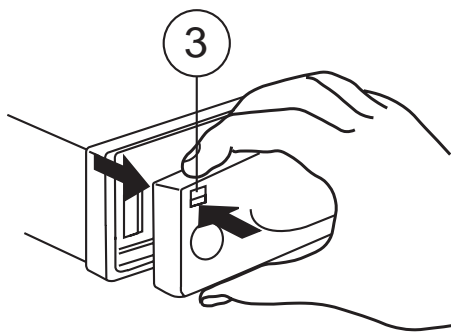

⇒ Press the  button ③.

The control panel latch mechanism opens.

⇒ First, pull the control panel straight off the device and then out towards the left.

- The device switches off after the control panel is detached.
- All the current settings are saved.
- Any CD already inserted in the device remains there.

Attaching the control panel

⇒ Slide the control panel from left to right into the device's guide.

⇒ Press the left edge of the control panel into the device until it clicks into place.

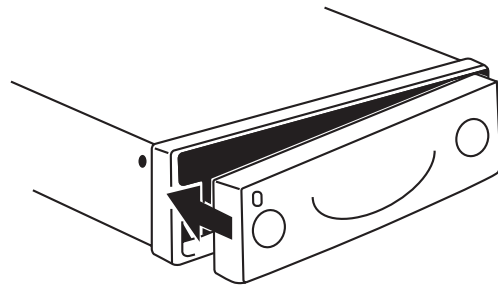

Note:

- When attaching the control panel, make sure you do not press the display.

Switching on/off

There are various ways of switching the device on/off.

Switching on/off using button

①

- ⇨ To switch on the device, press button ①.

The device switches on.

- ⇨ To switch off the device, press and hold down button ① for longer than two seconds.

The device switches off.

Switching on/off using the vehicle ignition

The device will switch on and off simultaneously with the ignition if it is connected correctly to the vehicle's ignition and if it was not previously switched off using button ①.

You can switch the device on even if the ignition is off.

- ⇨ Press button ①.

Note:

To protect the vehicle battery, the device will switch off automatically after one hour if the ignition is off.

Adjusting the volume

You can adjust the volume in steps from 0 (off) to 50 (maximum).

- ⇨ To increase the volume, turn the volume control ② clockwise.
- ⇨ To decrease the volume, turn the volume control ② anticlockwise.

Setting the power-on volume

You can set the default volume level at which the device plays when it is switched on.

- ⇨ Press the **MENU** button ⑨.
- ⇨ Press the softkey ⑤ assigned to the "VOLUME" display item.
- ⇨ Press the softkey ⑤ assigned to the "ON VOL" display item.
- ⇨ Set the volume level that you want using the volume control ②.
- ⇨ Press the joystick **OK** ⑧ or the **MENU** button ⑨ to close the menu.

The settings are saved.

Note:

You can also set the power-on volume to be the same as the volume level that was active before you switched off the device. To do so, press the softkey assigned to the "LAST VOL" display item in the volume menu.

⚠ Risk of injury! If the power-on volume is set to maximum, the volume level can be very high when the device is switched on.

If the volume was set to maximum before the device was switched off and the power-on volume is set to "LAST VOL", the volume level can be very high when the device is switched on again.

Severe damage to your hearing can be caused in both cases!

Volume mute

You can instantaneously reduce the volume (mute).

⇨ Briefly press button (1).

"MUTE" appears in the display.

Cancelling mute

⇨ Briefly press button (1) again.

or

⇨ turn the volume control (2).

Telephone audio

If your car sound system is connected to a mobile telephone, the sound system's volume will be muted as soon as you "pick up" the telephone. The telephone call is then outputted over the car sound system's loudspeakers. This requires that the mobile telephone is connected to the car sound system as described in the installation instructions.

If the sound system receives a traffic announcement during a telephone call, you will only be able to hear the traffic announcement after the call is finished (in so far as the traffic announcement is still being broadcast).

You can set the volume at which you want telephone calls to be initially heard.

⇨ Press the **MENU** button (9).

⇨ Press the softkey (5) assigned to the "VOLUME" display item.

⇨ Press the softkey (5) assigned to the "PHONE" display item in order to adjust the volume.

⇨ Set the volume level that you want using the volume control (2).

⇨ Press the joystick **OK** (8) or the **MENU** button (9) to close the menu.

The settings are saved.

Note:

You can also adjust the volume during the telephone call using the volume control (2).

Navigation audio

Instead of connecting a second external audio source ("AUX2", see "External audio sources") you can connect a navigation system.

If your car radio is connected to a navigation system and the navigation system outputs spoken information, the navigation voice output will be "mixed in" with the current audio source and will be outputted over the car radio's loudspeakers.

This requires that the navigation system is connected to the car radio (as described in the installation instructions) and activated in the menu.

You can find out from your Blaupunkt dealer which navigation systems can be used with your car sound system.

ADJUSTING THE VOLUME

Activating navigation audio

You can either connect a second external audio source or a navigation system to this device. If you do, you must specify which device is connected to this connection by selecting it in the menu.

- ⇨ Press the **MENU** button (9).
- ⇨ Press the softkey (5) assigned to the “AUX” display item.

The AUX menu is displayed.

- ⇨ If you have a navigation system connected, repeatedly press the softkey (5) assigned to the “NAV/AUX2” display item until the “NAVIGATION ON” setting appears.
- ⇨ Press the joystick **OK** (8) or the **MENU** button (9) to close the menu.

The settings are saved.

Setting the minimum navigation volume

You can set the volume level at which the navigation voice output is “mixed in” with the audio source.

Note:

- Set the volume on the navigation system to maximum. If the output sounds distorted, reduce the volume slightly on the navigation system.
- ⇨ Press the **MENU** button (9).
 - ⇨ Press the softkey (5) assigned to the “VOLUME” display item.

- ⇨ Press the softkey (5) assigned to the “NAVI DIFF” display item in order to adjust the volume.
- ⇨ Set the volume level that you want using the volume control (2).
- ⇨ Press the joystick **OK** (8) or the **MENU** button (9) to close the menu.

The settings are saved.

Note:

- You can also adjust the volume during the voice output using the volume control (2). This setting only applies to the current voice output and is not saved.

SOUND AND VOLUME DISTRIBUTION SETTINGS

Sound and volume distribution settings

Note:

You can adjust the bass and treble individually for each audio source.

Adjusting the bass

- ⇨ Press the **AUDIO** button (10).
- “AUDIO MENU” appears in the display.
- ⇨ Press the softkey (5) assigned to the “BASS” display item.
- ⇨ Move the joystick (8) up/right to boost the bass or move it down/left to reduce the bass.

When you have finished making your changes,

- ⇨ press the joystick **OK** (8) or the **AUDIO** button (10).

Adjusting the treble

- ⇨ Press the **AUDIO** button (10).
- “AUDIO MENU” appears in the display.
- ⇨ Press the softkey (5) assigned to the “TREBLE” display item.
- ⇨ Move the joystick (8) up/right to boost the treble or move it down/left to reduce the treble.

When you have finished making your changes,

- ⇨ press the joystick **OK** (8) or the **AUDIO** button (10).

Adjusting the right/left volume distribution (balance)

- ⇨ To adjust the balance, press the **AUDIO** button (10).
- “AUDIO MENU” appears in the display.
- ⇨ Press the softkey (5) assigned to the “BALANCE” display item.
- ⇨ Move the joystick (8) up/right or down/left to adjust the right/left volume distribution.

When you have finished making your changes,

- ⇨ press the joystick **OK** (8) or the **AUDIO** button (10).

Adjusting the front/back volume distribution (fader)

- ⇨ To adjust the fader, press the **AUDIO** button (10).
- “AUDIO MENU” appears in the display.
- ⇨ Press the softkey (5) assigned to the “FADER” display item.
- ⇨ Move the joystick (8) up/right or down/left to adjust the front/back volume distribution.

When you have finished making your changes,

- ⇨ press the joystick **OK** (8) or the **AUDIO** button (10).

X-BASS

The X-BASS feature can be used to boost the bass at low volume levels. You can set the X-Bass boost for **one** of the following frequencies: 32 Hz, 40 Hz, 50 Hz, 63 Hz or 80 Hz in steps from 0 - 6. If you select the 0 setting, the X-Bass function will be deactivated.

- ⇨ Press the **AUDIO** button (10).
- “AUDIO MENU” appears in the display.
- ⇨ Press the softkey (5) assigned to the “X-BASS” display item.
- ⇨ Move the joystick (8) left or right to select the frequency that you want to boost.
- ⇨ Move the joystick (8) up to boost the X-BASS or move it down to reduce the X-BASS.

When you have finished making your changes,

- ⇨ press the joystick **OK** (8) or the **AUDIO** button (10).

Adjusting the display settings

You can adjust the display settings to suit the installation position in your vehicle and your own preferences.

Adjusting the viewing angle

- ⇨ Press the **MENU** button (9).
- ⇨ Press the softkey (5) assigned to the “DISPLAY” display item.
- ⇨ Press the softkey (5) assigned to the “ANGLE” display item.
- ⇨ Move the joystick (8) up/right or down/left to adjust the viewing angle.
- ⇨ Press the joystick **OK** (8) or the **MENU** button (9) to close the menu.

The settings are saved.

Adjusting the display brightness

If your car sound system is connected as described in the installation instructions, the display brightness will change when the headlights are turned on/off. The display brightness can be adjusted separately for night and day in steps ranging from 1-16.

Display brightness

- ⇨ Press the **MENU** button (9).
- ⇨ Press the softkey (5) assigned to the “DISPLAY” display item.
- ⇨ Press the softkey (5) assigned to the “BRIGHT” display item.

ADJUSTING THE DISPLAY SETTINGS

DAY and NIGHT are displayed in the top display line together with the currently set values.

- ⇨ Move the flashing selection marker behind DAY or NIGHT by pressing the joystick (8) to the left or right.
- ⇨ Set the value that you want. To do so, move the joystick (8) down or up.
- ⇨ Press the joystick **OK** (8) or the **MENU** button (9) to close the menu.

The settings are saved.

Setting the button illumination colour

You can choose the colour of the device's button illumination.

There are 16 colours for you to choose from.

- ⇨ Press the **MENU** button (9).
- ⇨ Press the softkey (5) assigned to the "DISPLAY" display item.
- ⇨ Press the softkey (5) assigned to the "KEYCOLOR" display item.
- ⇨ Move the joystick (8) up/right or down/left to adjust the colour. A different colour is selected every time you move the joystick.
- ⇨ Press the joystick **OK** (8) or the **MENU** button (9) to close the menu.

The settings are saved.

Setting the display illumination colour

When setting the display illumination, you can choose one of four preset colours or mix a colour yourself from the RGB spectrum (red-green-blue) or select a colour during a colour scan.

Selecting a preset colour

Four different colours are already stored in the device. "Ocean" (blue), "Amber", "Sunset" (red-orange) and "Nature" (green) are available. Select a colour that best suits your vehicle interior.

- ⇨ Press the **MENU** button (9).
- ⇨ Press the softkey (5) assigned to the "DISPLAY" display item.
- ⇨ Press the softkey (5) assigned to the "COLOR" display item.
- ⇨ Press the softkey (5) assigned to the display item of the colour that you want.
- ⇨ Press the joystick **OK** (8) or the **MENU** button (9) to close the menu.

The settings are saved.

Mixing a colour for the display illumination

To customise the display illumination to suit your tastes you can mix a colour yourself using the three primary colours red, blue and green.

- ⇨ Press the **MENU** button (9).
- ⇨ Press the softkey (5) assigned to the "DISPLAY" display item.

ADJUSTING THE DISPLAY SETTINGS

- ⇒ Press the softkey (5) assigned to the “COLOR” display item.
- ⇒ Press the softkey (5) assigned to the “USER” display item.
- ⇒ In the following menu you can set the red, blue and green colour components yourself. To do so, press the appropriate softkey (5) repeatedly until the displayed colour suits your tastes.
- ⇒ Press the joystick **OK** (8) or the **MENU** button (9) to close the menu.

The settings are saved.

Selecting a display illumination colour during a colour scan

- ⇒ Press the **MENU** button (9).
- ⇒ Press the softkey (5) assigned to the “DISPLAY” display item.
- ⇒ Press the softkey (5) assigned to the “COLOR” display item.
- ⇒ Press the softkey (5) assigned to the “COL-SCAN” display item.

The device starts changing the display illumination colour.

- ⇒ If you want to select one of the colours, press the softkey (5) assigned to the “SAVE” display item.
- ⇒ If you want to switch back to the previous menu without changing the colour, press the softkey (5) assigned to the “BREAK” display item.

- ⇒ Press the joystick **OK** (8) or the **MENU** button (9) to close the menu.

The settings are saved.

Configuring the spectrum analyser

The spectrum analyser in your display provides a symbolic representation of the sound system’s output level. If the spectrum analyser is switch on, it will appear automatically after a short time if you refrain from pressing a button whilst an audio source is playing.

You can also choose to deactivate the spectrum analyser.

Switching the spectrum analyser on/off

- ⇒ Press the **MENU** button (9).
- ⇒ Press the softkey (5) assigned to the “DISPLAY” display item.
- ⇒ Repeatedly press the softkey (5) assigned to the “SPECTRUM” display item until the “SPECTRUM OFF” or “SPECTRUM ON” setting that you want is displayed in the top display line.
- ⇒ Press the joystick **OK** (8) or the **MENU** button (9) to close the menu.

The settings are saved.

Inverting the appearance of the display content

You can invert the appearance of the display content.

- ⇒ Press the **MENU** button (9).
- ⇒ Press the softkey (5) assigned to the “DISPLAY” display item.
- ⇒ Press the softkey (5) assigned to the “INVERT” display item.
- ⇒ Press the joystick **OK** (8) or the **MENU** button (9) to close the menu.

The settings are saved.

Radio mode

This device is equipped with an RDS radio receiver. Many of the receivable FM stations broadcast a signal that not only carries the programme but also additional information such as the station name and programme type (PTY).

The station name appears in the display as soon as the tuner receives it. You can optionally display the programme type. For further details, please read the section entitled “Programme type (PTY)”.

Adjusting the tuner settings

To ensure that the tuner works properly, the device must be configured for the region in which you are using it. You can choose between Europe/ Asia/ Gulf States (AREA EUR) and North/South America (AREA USA). If you experience problems with radio reception, please check this setting.

- ⇒ Press the **MENU** button (9).
- ⇒ Press the softkey (5) assigned to the “TUNER” display item.
- ⇒ Press the softkey (5) assigned to the display item of the region that you want: “AREA EUR” or “AREA USA”.
- ⇒ Press the joystick **OK** (8) or the **MENU** button (9) to close the menu.

The settings are saved.

RADIO MODE

Setting the number of antennas

This device is equipped with two RDS radio receivers (TwinCeiver).

You can connect one or two antennas to the device. If two antennas are connected (strongly recommended - the second antenna is included), you can use directional reception when tuning into stations in DDA radio mode. Directional reception considerably improves reception quality in most cases.

Note:

To ensure that the tuner works correctly, the main antenna must be connected to the lower antenna jack.

To set the number of antennas,

- ⇨ press the **MENU** button (9).
- ⇨ Press the softkey (5) assigned to the "TUNER" display item.
- ⇨ Press the softkey (5) assigned to the "ONE ANTE" display item if one antenna is connected to the device.

or

- ⇨ Press the softkey (5) assigned to the "TWO ANTE" display item if two antennas are connected to the device.
- ⇨ Press the joystick **OK** (8) or the **MENU** button (9) to close the menu.

The settings are saved.

Switching to radio mode

If you are in CD/MP3 mode or CD-changer/Compact Drive MP3 mode,

- ⇨ press the **TUNER** button (13).

The main radio menu for tuning into a station is displayed. You can control the radio-mode functions in the radio functions menu. You can open the radio functions menu by pressing the **TUNER** button (13) again while in radio mode.

Selecting static/dynamic radio mode (only FM)

You can choose between two modes for FM radio:

Static radio mode ("PRESETS" and "DDA")

In static FM radio mode there are four memory banks (FM1, FM2, FM3 and FMT) at your disposal. You can store six stations in each of these memory banks. The receiver automatically tunes into the best receivable frequency for any station that you access from memory.

PRE mode (static)

- If you only have **one** antenna connected to the device and you configured it in the setup menu (see "Setting the number of antennas"), the device uses one tuner to play the tuned station while at the same time using the second tuner to search continuously for the best available frequency for the tuned station (if the RDS function is activated).

DDA digital directional antenna mode (static)

- If you have **two** antennas connected to the device and configured them in the setup menu (see “Setting the number of antennas”), the tuned station will be received in DDA radio mode using both antennas. The TwinCeiver continuously analyses the signals from both antennas and uses them to calculate a “clean signal” in order to reduce reception interference. This process developed by Blaupunkt has a similar effect to using a directional antenna. Reception quality is improved considerably, particularly in areas suffering from reception interference due to reflections off buildings and hills, etc. In exceptional cases, for instance if two different stations are received on the same frequency, an undesirable effect will be the result. If this is the case, you should select dynamic radio mode (see “Selecting the radio mode” below).

Dynamic radio mode

There are five memory banks (DL1 - DL5) at your disposal in dynamic radio mode.

Whilst the station that is tuned in is being played, the second receiver searches in the background for receivable stations and displays the abbreviated names of all receivable stations alongside the softkeys in the memory bank. The stations are continuously updated ensuring that you always have access to all receivable stations.

Selecting the radio mode

To switch between static and dynamic modes,

- ⇒ press the **TUNER** button (13) in radio mode.

The radio functions menu appears in the display.

- ⇒ Press the **NEXT** button (4).

The second page of the radio functions menu is displayed.

- ⇒ Press the softkey (5) assigned to the “TUNER 2” display item.
- ⇒ Press the softkey (5) assigned to the “DYN LIST” display item for dynamic radio mode.
- ⇒ Press the softkey (5) assigned to the “DDA” or “PRESETS” display item for one of the static radio modes.
- ⇒ Press the joystick **OK** (8) or the **MENU** button (9) to close the menu.

The settings are saved.

RADIO MODE

RDS function

The RDS function extends your radio's range of functions (only in FM radio mode). If the RDS function is activated, the device automatically tunes into the best receivable frequency for the station that is currently set.

Switching the RDS function on/off

To use the RDS function,

- ⇨ press the **TUNER** button (13) while in radio mode.

The radio functions menu appears in the display.

- ⇨ Repeatedly press the softkey (5) assigned to the "RDS" display item until the "RDS ON" or "RDS OFF" setting that you want is displayed.

To return to the main radio menu,

- ⇨ press the **TUNER** button (13) or the joystick **OK** (8).

The settings are saved.

Selecting the waveband / memory bank

You can use this device to receive programmes broadcast over the FM, AM and SW wavebands. There are four memory banks for the FM waveband, three memory banks for the AM waveband and one memory bank for SW.

You have up to five memory banks at your disposal in dynamic radio mode.

Six stations can be stored in each memory bank.

Selecting the waveband

To select the FM, AM or SW waveband,

- ⇨ press the **TUNER** button (13) while in radio mode.

The radio functions menu appears in the display.

- ⇨ Press the softkey (5) assigned to the "BAND" display item.
- ⇨ Press the softkey (5) assigned to the "FM" display item for the FM waveband.
- ⇨ Press the softkey (5) assigned to the "AM" display item for the AM waveband.
- ⇨ Press the softkey (5) assigned to the "SW" display item for the SW waveband.

The main radio menu for the selected waveband is displayed.

Selecting an FM/AM memory bank

To switch between the FM memory banks (FM1, FM2, FM3 and FMT) or AM memory banks (AM1, AM2 and AMT),

- ⇨ press the **NEXT** button (4) repeatedly until the memory bank that you want appears in the display.

The memory banks are accessed in the following order: FM1, FM2, FM3, FMT or AM1, AM2, AMT.

Tuning into a station

There are various ways of tuning into a station.

Automatic station seek tuning

- ⇨ Move the joystick (8) down or up.

The radio tunes into the next receivable station.

Tuning into stations manually

You can also tune into stations manually.

Note:

You can only tune into stations manually if the RDS function is deactivated.

- ⇨ Move the joystick (8) left or right.

Setting the sensitivity of station seek tuning

You can choose whether the radio should only tune into stations providing good reception or whether it can also tune into those with a weak reception.

- ⇨ Press the **TUNER** button (13) while in radio mode.

The radio functions menu appears in the display.

- ⇨ Press the **NEXT** button (4).

Note:

If you open the radio functions menu while in AM or SW radio mode, the softkey assigned to the "SENS" display item will appear on the first page.

- ⇨ Press the softkey (5) assigned to the "SENS" display item.

- ⇨ Press the softkey (5) assigned to the "FM" or "AM" display item to adjust the sensitivity for "FM" or "AM".

- ⇨ Move the joystick (8) up/right or down/left to adjust the sensitivity.

You can adjust the sensitivity in steps from 1 to 6. "SENSITIVITY 1" is the lowest setting and "SENSITIVITY 6" is the highest sensitivity setting for distant stations.

- ⇨ Press the joystick **OK** (8) or the **MENU** button (9) to close the menu.

The settings are saved.

Scanning receivable stations (SCAN)

You can use the scan function to briefly play all the receivable stations.

You can set the scanning time to between 5 and 30 seconds in the menu.

Starting SCAN

- ⇨ Press and hold down the joystick **OK** (8) for longer than two seconds.

Scanning begins. "SCAN" appears briefly in the display followed by the current station name or frequency of the station.

Cancelling SCAN and continuing listening to a station

- ⇨ Press the joystick **OK** (8).

Scanning stops and the radio continues playing the station that it tuned into last.

RADIO MODE

Setting the scanning time

- ⇨ Press the **MENU** button (9).
- ⇨ Press the softkey (5) assigned to the “VARIOUS” display item.
- ⇨ Press the softkey (5) assigned to the “SCANTIME” display item.
- ⇨ Move the joystick (8) up/right or down/left to adjust the scanning time.
- ⇨ Press the joystick **OK** (8) or the **MENU** button (9) to close the menu.

The settings are saved.

Note:

- The scanning time that you set is also applied by the system to scanning carried out in CD/MP3 mode and CD-changer mode.

Storing stations

Storing stations manually

- ⇨ Select the memory bank that you want (FM1, FM2, FM3, FMT or AM1, AM2, AMT) or the SW waveband.
- ⇨ Tune into the station that you want as described in the section entitled “Tuning into a station”.
- ⇨ Press one of the six softkeys for longer than two seconds to assign the station to that softkey.

Storing stations automatically (Travelstore)

In static radio mode you can automatically store the six stations providing the best reception in the region (only FM and AM). The stations are stored in the FMT or AMT memory bank.

Note:

Any stations that were previously stored in this memory bank are deleted in the process.

Starting the Travelstore function

- ⇨ Press the **TUNER** button (13) while in radio mode.

The radio functions menu appears in the display.

- ⇨ Press the softkey (5) assigned to the “T-STORE” display item.

The storing procedure begins. “TRAVEL STORE” appears in the display. After the process is completed, the radio will play the station that is stored in location 1 of the FMT (or AMT) memory bank.

Listening to stored stations

- ⇨ Select the memory bank or waveband.
- ⇨ Press the softkey (5) that is assigned to the station name or frequency of the station that you want to listen to.

Programme type (PTY)

Besides transmitting the station name, some FM stations also provide information on the type of programme that they are broadcasting. Your car radio can receive and display this information.

For example, the programme types can be:

CULTURE	TRAVEL	JAZZ
SPORT	NEWS	POP
ROCK	CLASSICS	

You can use the PTY function to select stations of a particular programme type.

Note:

If the tuner does not find a station that corresponds to the selected programme type, you will hear a beep and “NO PTY” appears briefly in the display. The radio will then retune to the station that it received last.

Activating PTY

To use the PTY function,

- ⇨ press the **TUNER** button (13) while in radio mode.

The radio functions menu appears in the display.

- ⇨ Press the **NEXT** button (4).
- ⇨ Press the softkey (5) assigned to the “PROG TYP” display item.

If PTY is activated, the display shows the current programme type. PTY lights up in the display. The programme types are displayed alongside the softkeys (5).

Deactivating PTY

To switch off the PTY function,

- ⇨ Whilst the programme types are being displayed, press the softkey (5) assigned to the “PTY OFF” display item.

Selecting a programme type and starting seek tuning

The PTY menu comprises several pages on which the known programme types are displayed. To browse through the PTY menu’s pages,

- ⇨ press the **NEXT** button (4) repeatedly until the programme type that you want appears alongside one of the softkeys.
- ⇨ Press the softkey (5) assigned to the programme type that you want.
- ⇨ Move the joystick (8) up/right or down/left to start seek tuning.

The next receivable station corresponding to your selected programme type will then be tuned into.

If the tuner does not find a station that corresponds to the selected programme type, you will hear a beep and “NO PTY” appears briefly in the display. The radio will then retune to the station that it received last.

Note:

If you want to switch back to the programme types display,

- ⇨ open the second page of the radio functions menu again and press the softkey (5) assigned to the “PROG TYP” display item.

RADIO MODE

Optimising radio reception

Treble reduction feature during interference (HiCut)

The HiCut function has the effect of reducing interference noise during poor radio reception. If interference occurs, the system automatically reduces the treble thus reducing the interference level.

Setting HiCut

⇒ Press the **TUNER** button (13) while in radio mode.

The first page of the radio functions menu is displayed.

⇒ Press the **NEXT** button (4).

⇒ Repeatedly press the softkey (5) assigned to the “HIGH CUT” display item until the setting that you want appears in the display.

“HICUT 0” means that no automatic reduction of the treble and interference level will be made; “HICUT 2” means that a maximum reduction will be made.

⇒ Press the joystick **OK** (8) or the **TUNER** button (13) to close the menu.

The settings are saved.

Activating/deactivating the radio text display

Some stations use the RDS signal to broadcast scrolling texts known as radio texts. You can allow radio texts to be displayed or you can block them.

⇒ Press the **TUNER** button (13) while in radio mode.

The radio functions menu appears in the display.

⇒ Repeatedly press the softkey (5) assigned to the “R-TEXT” display item until the “RADIO TEXT ON” or “RADIO TEXT OFF” setting that you want is displayed.

⇒ Press the **TUNER** button (13) or the joystick **OK** (8).

The settings are saved.

CD mode

You can use this device to play standard CDs with a diameter of 12 cm. CD-Rs and CD-RWs (CDs that you have “burned” yourself) can generally also be played. Due to the varying quality of CD blanks, Blaupunkt cannot guarantee that this will work properly. To ensure the system functions properly, only use CDs labelled with the compact disc logo. Problems might be experienced when trying to play copy-protected CDs. Blaupunkt cannot guarantee the proper functioning of copy-protected CDs! To avoid problems when playing CDs, you should not burn CDs at speeds greater than 16-speed.

 Risk of severe damage to the CD drive! CD singles with a diameter of 8 cm and non-circular contoured CDs (shape CDs) must not be used. We accept no responsibility for any damage to the CD drive that may occur as a result of the use of unsuitable CDs.

Switching to CD mode and inserting a CD

- If there is no CD inserted in the device yet,
- ⇒ press the  button (7).

The control panel opens out towards you.

- ⇒ Insert the CD with the printed side uppermost into the CD compartment.

The drive draws in the CD.

You must not hinder or assist the drive as it draws in the CD.

The control panel closes automatically.

The CD menu appears and the CD starts playing.

- If a CD is already inserted in the device,
- ⇒ press the **SOURCE** button (12) repeatedly until CD mode is displayed.

The CD menu appears and playback begins from the point at which it was last interrupted.

Ejecting a CD

- ⇒ press the  button (7).

The control panel opens out towards you and the CD is ejected.

- ⇒ Carefully remove the CD.
- ⇒ Press the  button (7).

The control panel closes.

Selecting tracks

- ⇒ Move the joystick (8) in one direction (up or right for the next track or down or left for the previous track) until the number of the track that you want appears in the display.

If you press the joystick (8) downwards once or to the left once, the current track will be played again from the beginning.

CD MODE

Fast searching (audible)

To fast search backwards or forwards,

- ⇨ press and hold down the joystick **8** in one direction (up or right for forwards or down or left for backwards) until fast searching begins.

Random track play (MIX)

- ⇨ Press the softkey **5** assigned to the “MIX” display item.

“MIX CD” appears briefly in the display. The next track to be played will be picked at random.

Cancelling MIX

- ⇨ Press the softkey **5** assigned to the “MIX” display item again.

“MIX OFF” appears briefly in the display.

Repeating tracks (REPEAT)

- ⇨ Press the softkey **5** assigned to the “REPEAT” display item.

“REPEAT TRACK” appears briefly in the display. The track is repeated continuously until you deactivate REPEAT.

Cancelling REPEAT

- ⇨ Press the softkey **5** assigned to the “REPEAT” display item again.

“REPEAT OFF” appears briefly in the display.

Normal playback is then resumed.

Scanning tracks (SCAN)

You can briefly play (scan) all the tracks on the CD.

- ⇨ Press and hold down the joystick **OK 8** for longer than two seconds.

The subsequent tracks on the CD are briefly played in ascending order.

Note:

- You can set the scanning time. For further details, please read the section entitled “Setting the scanning time” in the “Radio mode” chapter.

Cancelling SCAN and continuing listening to a track

To cancel scanning,

- ⇨ press the joystick **OK 8**.

The currently scanned track will then continue to be played normally.

Displaying CD text

Some CDs include CD text. The CD text might contain the names of the artist, album and tracks.

You can allow the CD text to be displayed as scrolling text in the bottom line of the display every time you switch to another track.

If the inserted CD does not contain any CD text, “NO TEXT” will appear briefly in the display if the CD text feature is activated.

Switching CD text on/off

- ⇒ Repeatedly press the softkey ⑤ assigned to the “TEXT” display item until “CD TEXT ON” or “CD TEXT OFF” is displayed.

Setting scrolling text

You can allow the CD text to be displayed as scrolling text in the bottom line of the display.

Switching CD scrolling text on/off

- ⇒ Repeatedly press the softkey ⑤ assigned to the “SCROLL” display item until “SCROLL ON” or “SCROLL OFF” is displayed.

MP3 mode

You can also use this car sound system to play CD-Rs and CD-RWs that contain MP3 music files.

Preparing an MP3-CD

The various combinations of CD burners, CD burning software and CD blanks may lead to problems arising with the device’s ability to play certain CDs. If problems occur with your own burned CDs, you should try another brand of CD blank or choose another colour of CD blank. To avoid problems when playing CDs, you should not burn CDs at speeds greater than 16-speed.

The format of the CD must be ISO 9660 Level 1 or Level 2 or Joliet. Other formats cannot be played reliably.

Avoid multi-sessions. If you write more than one session to the CD, only the first session will be detected.

You can create a maximum of 127 directories on a CD. You can use this device to access each of these directories.

Each directory can in turn contain up to 254 tracks and subdirectories that can also be accessed. A maximum of 8 levels of directories are allowed.

MP3 MODE

Fig. 1

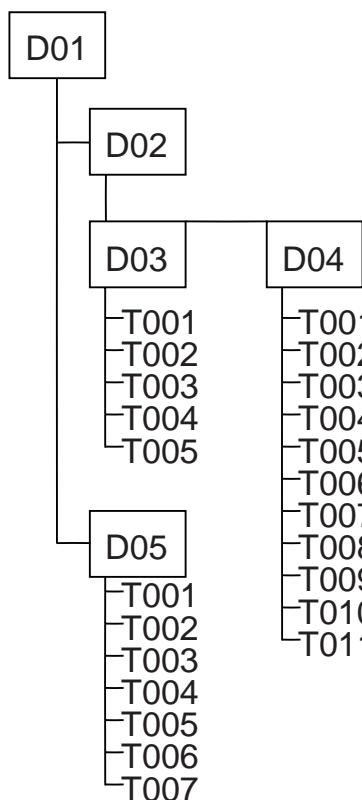

Since using some burner software can lead to inconsistencies in the way items are numbered, you should ensure that the root directory D01 either contains only subdirectories containing tracks (Fig. 1) or only tracks (Fig. 2).

You can name each directory using a PC. The device is capable of displaying the directory name. Name the directories and tracks using your CD burner software. The software's instruction manual will provide details on how to do this.

Note:

- When naming directories and tracks you should avoid using accents and special characters.

Fig. 2

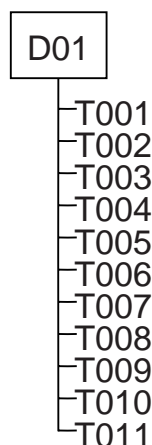

If you like your files to be in the correct order, you should use burner software that places files in alphanumerical order. If your software does not provide this feature you also have the option of sorting the files manually. To do so, you should place a number (e.g. "001", "002", etc.) at the beginning of each file name - you must include the leading zeros.

MP3 tracks can contain additional information such as the artist, album and track names (ID3 tags). This device can display version 1 ID3 tags.

This device can only play MP3 files that have the ".MP3" file extension.

Note:

To ensure uninterrupted playback,

- do not try changing the file extension to ".MP3" of any files other than MP3 files and then attempt to play them!
- Do not use "mixed" CDs containing both non-MP3 data and MP3 tracks.
- Do not use mix-mode CDs containing both audio tracks and MP3 tracks.

Switching to MP3 mode

MP3 mode is activated in the same way as normal CD mode. For further details, please read the section entitled "Switching to CD mode / Inserting a CD" in the "CD mode" chapter.

Selecting a directory

Selecting from the directory list

You can display a list of all the directories on the inserted CD and then conveniently select a directory from it. The directories are displayed with the names that you created when burning the CD.

- ⇨ Press the **NEXT** button (4) whilst an MP3 is playing.

The track list is displayed for the current directory.

- ⇨ Move the joystick (8) to the left or right to switch to the directory list.
- ⇨ Press the joystick (8) up or down to browse through the list.
- ⇨ If you want to select a directory from the list, move the selection marker to the directory that you want and press the joystick **OK** (8).

The list of tracks in the selected directory is displayed.

- ⇨ Move the selection marker to the track that you want and press the joystick **OK** (8).
- ⇨ Press the **NEXT** button (4) to display the main MP3 menu again.

Selecting a directory using the joystick

To move up or down to another directory,

- ⇨ repeatedly press the joystick (8) up or down until the number of the directory that you want appears at the very beginning of the top line of the display.

Note:

- Any directories not containing MP3 files will be skipped automatically. If, for instance, you are listening to tracks in directory D01 and you select the next directory by pressing the joystick (8), directory D02 (which does not contain any MP3 tracks) will be skipped and D03 will be played (see diagram). The display will then automatically switch from “D02” to “D03”.

Selecting tracks

Selecting tracks from a track list

You can display a list of all the tracks in the current directory and then conveniently select a track from it.

- ⇨ To display the track list, press the **NEXT** button (4).
- ⇨ Press the joystick (8) up or down to browse through the track list.
- ⇨ If you want to select a track from the list, move the selection marker to the track that you want and press the joystick **OK** (8).
- ⇨ Press the **NEXT** button (4) to display the main MP3 menu again.

Selecting tracks using the joystick

To move up or down to another track in the current directory,

- ⇨ move the joystick (8) to the right for the next track or to the left for the previous track until the number of the track that you want appears in the display.

MP3 MODE

If you press the joystick **8** to the left once, the current track will be played again from the beginning.

Fast searching (audible)

To fast search backwards or forwards,

- ⇨ press and hold down the joystick **8** to the left or right until fast searching backwards/forwards begins.

Scanning tracks (SCAN)

You can briefly play (scan) all the tracks on the CD.

- ⇨ Press and hold down the joystick **OK 8** for longer than two seconds.

The subsequent tracks on the CD are briefly played in ascending order.

Note:

- You can set the scanning time. For further details, please read the section entitled "Setting the scanning time" in the "Radio mode" chapter.

Cancelling SCAN and continuing listening to a track

To cancel scanning,

- ⇨ press the joystick **OK 8**.

The currently scanned track will then continue to be played normally.

Random track play (MIX)

To play the tracks in the current directory in random order,

- ⇨ press the softkey **5** assigned to the "MIX" display item.

"MIX DIR" appears in the display.

To play the tracks contained in all the directories on the inserted MP3-CD in random order,

- ⇨ press the softkey **5** assigned to the "MIX" display item again.

"MIX CD" appears in the display.

Cancelling MIX

To cancel MIX,

- ⇨ repeatedly press the softkey **5** assigned to the "MIX" display item until "MIX OFF" appears in the display.

Repeating individual tracks or whole directories (REPEAT)

- ⇨ Press the softkey **5** assigned to the "REPEAT" display item.

"REPEAT TRACK" appears briefly in the display.

To repeat the whole directory,

- ⇨ press the softkey **5** assigned to the "REPEAT" display item again.

"REPEAT DIR" appears briefly in the display.

Cancelling REPEAT

To stop the current track or current directory from being repeated,

- ⇨ repeatedly press the softkey **5** that is assigned to the “REPEAT” display item until “REPEAT OFF” appears briefly in the display.

Configuring the display

There are various options available for displaying the name of the artist, track and album (ID3 tag) or the directory and file name. The information contained in the ID3 tag (album, artist and track) can only be displayed if it was saved when the CD and MP3 file were created.

The track name is always displayed in the top line of the display during playback. The track name appears once as scrolling text after a track change and is then abbreviated to 16 characters and displayed.

Note:

If the track name is not available in the ID3 tag, the system will display the file name instead.

You can choose between different items of information to be displayed in the bottom line of the display (info line).

Selecting information in the info line

In the bottom line of the display (info line) you can choose between displaying the various items of MP3 information such as track, artist, album or directory number (DIR) / file name.

- ⇨ Repeatedly press the softkey **5** assigned to the “INFO” display item until the display that you want appears in the bottom line of the display.

Note:

If the information on the artist, track and album is not available in the form of an ID3 tag, you will not be able to select it.

Displaying all of the information for a file once

To display all of the available information for a track as well as the directory name and file name (info displayed once as scrolling text),

- ⇨ press the softkey **5** assigned to the “SHOW ALL” display item.

If available, the information is displayed once as scrolling text in the info line. “SHOW ALL” flashes in the display whilst the information is being shown.

Setting scrolling text

You can choose whether you want the display that you set under “Selecting information in the info line” to appear as scrolling text (“SCROLL ON”) or only once (“SCROLL OFF”).

- ⇨ Repeatedly press the softkey **5** assigned to the “SCROLL” display item until the setting that you want appears.

CD-CHANGER MODE

CD-changer mode (optional)

To find out which CD changers / Compact Drive MP3 can be used with this device, please refer to the "Accessories" chapter in these instructions or contact your Blaupunkt dealer.

Note:

Information on handling CDs, inserting CDs and operating the CD changer can be found in the operating instructions supplied with your CD changer.

Information on using the Compact Drive MP3 and recording music tracks onto the Compact Drive MP3's Microdrive™ hard disk can be found in the operating instructions supplied with the Compact Drive MP3.

Switching to CD-changer mode

⇒ Press the **SOURCE** button (12) repeatedly until "CDC" is displayed.

Playback continues from the point at which it was last interrupted.

If the magazine was removed from the CD changer and then replaced, the CD magazine will first be scanned, and playback will begin from the first track on the first CD that the CD changer detects.

Selecting CDs

To move up or down to another CD,

⇒ press the softkey (5) assigned to the display item of the CD that you want (CD1 - CD10). To do so you might need to switch "pages" in the main CD-changer menu by pressing the softkey (5) assigned to the "NEXT" or "PREVIOUS" display item.

or

⇒ repeatedly press the joystick (8) up or down until the number of the CD that you want appears in the display.

Selecting tracks

To move down or up to another track on the current CD,

⇒ repeatedly press the joystick (8) to the left or right until the number of the track that you want is displayed.

If you press the joystick (8) once to the left, the current track will be played again from the beginning.

Fast searching (audible)

To fast search forwards or backwards,

⇒ press and hold down the joystick (8) to the left or right until fast searching backwards/forwards begins.

Scanning tracks (SCAN)

You can briefly play (scan) all the tracks on the CD.

- ⇨ Press and hold down the joystick **OK** (8) for longer than two seconds.

The subsequent tracks on the CD are briefly played in ascending order.

Note:

- You can set the scanning time. For further details, please read the section entitled “Setting the scanning time” in the “Radio mode” chapter.

Cancelling SCAN and continuing listening to a track

To cancel scanning,

- ⇨ press the joystick **OK** (8).

The currently scanned track will then continue to be played normally.

Repeating individual tracks or whole CDs (REPEAT)

To repeat the current track,

- ⇨ press the **NEXT** button (4).

The CD-changer functions menu appears.

- ⇨ Press the softkey (5) assigned to the “REPEAT” display item.

“REPEAT TRACK” appears briefly in the display.

To repeat the whole CD,

- ⇨ press the softkey (5) assigned to the “REPEAT” display item again whilst the CD-changer functions menu is being displayed.

“REPEAT CD” appears briefly in the display.

Cancelling REPEAT

To stop the current track or current CD from being repeated,

- ⇨ repeatedly press the softkey (5) assigned to the “REPEAT” display item again (whilst the CD-changer functions menu is being displayed) until “REPEAT OFF” appears briefly in the display.

Random track play (MIX)

To play the tracks on the current CD in random order,

- ⇨ press the **NEXT** button (4).

The CD-changer functions menu appears.

- ⇨ Press the softkey (5) assigned to the “MIX” display item.

“MIX CD” appears in the display.

To play the all the tracks on all inserted CDs in random order,

- ⇨ press the softkey (5) assigned to the “MIX” display item again.

“MIX ALL” appears in the display.

Cancelling MIX

To cancel MIX,

- ⇨ repeatedly press the softkey (5) assigned to the “MIX” display item until “MIX OFF” appears briefly in the display.

CD-CHANGER MODE

Naming CDs

The car sound system allows you to assign names for up to 99 CDs (not with the Compact Drive MP3) so that you can recognise them more easily. The names can be a maximum of seven characters long.

“FULL” will appear in the display if you try assigning more than 99 names.

Entering/editing CD names

- ⇨ Listen to the CD that you want to name.
- ⇨ Press the **NEXT** button (4).

The CD-changer functions menu appears.

- ⇨ Press the softkey (5) assigned to the “CD NAME” display item.

The current name of the CD is displayed in the top line of the display. If the CD has not been named yet, seven underscores “_” will be displayed instead.

- ⇨ Press the softkey (5) assigned to the “EDIT” display item.

You will now enter edit mode. The first input position flashes.

- ⇨ Move the joystick (8) up or down to select the character that you want. If you want an empty space, simply select the underscore.
- ⇨ Move the joystick (8) to the left or right to change the input position.
- ⇨ To save the name, press the joystick **OK** (8).

Deleting a CD name

- ⇨ Listen to the CD whose name you want to delete.
- ⇨ Press the **NEXT** button (4).

The CD-changer functions menu appears.

- ⇨ Press the softkey (5) assigned to the “CD NAME” display item.
- ⇨ Press and hold down the softkey (5) assigned to the “CLEAR CD” display item for longer than two seconds.

The CD name will be deleted.

Deleting all CD names

- ⇨ Listen to a CD.
- ⇨ Press the **NEXT** button (4).

The CD-changer functions menu appears.

- ⇨ Press the softkey (5) assigned to the “CD NAME” display item.
- ⇨ Press and hold down the softkey (5) assigned to the “CLEAR ALL” display item for longer than two seconds.

The CD names will be deleted.

Note:

This function is not available for the Compact Drive MP3. If you use this function with the Compact Drive MP3, “CDC CLEAR” is displayed for 45 seconds. You will not be able operate the device during this time period.

CLOCK time

Setting the clock time

The clock can be set automatically using the RDS signal. You can also set the clock manually if you cannot receive a radio station that supports this feature.

Setting the clock automatically

To set the clock automatically,

- ⇨ press the **MENU** button (9).
- ⇨ Press the softkey (5) assigned to the “CLOCK” display item.
- ⇨ Repeatedly press the softkey (5) assigned to the “AUTOSYNC” display item until “AUTOSYNC ON” appears in the display.

“AUTOSYNC ON” means that the clock is set automatically using the RDS signal.

Setting the clock manually

- ⇨ To set the clock, press the **MENU** button (9).
- ⇨ Press the softkey (5) assigned to the “CLOCK” display item.
- ⇨ Press the softkey (5) assigned to the “TIME” display item.

The hours and minutes are displayed in the top line of the display. The hours flash.

- ⇨ Adjust the hours by moving the joystick (8) up or down.

To adjust the minutes,

- ⇨ press the joystick (8) to the right.

The minutes flash.

- ⇨ Adjust the minutes by moving the joystick (8) up or down.
- ⇨ Press the joystick **OK** (8) or the **MENU** button (9) to close the menu.

The settings are saved.

Setting the date

To set the date,

- ⇨ press the **MENU** button (9).
- ⇨ Press the softkey (5) assigned to the “CLOCK” display item.
- ⇨ Press the softkey (5) assigned to the “DATE” display item.

The year (YY), month (MM) and day (DD) appear in the top line of the display.

The input position for year flashes.

- ⇨ Set the year (e.g. “04” for 2004) by moving the joystick (8) up or down.
- ⇨ Move the joystick (8) to the right to switch the input position to month.
- ⇨ Set the month by moving the joystick (8) up or down.
- ⇨ Press the joystick (8) to the right to switch the input position to day.
- ⇨ Set the day by moving the joystick (8) up or down.
- ⇨ Press the joystick **OK** (8) or the **MENU** button (9) to close the menu.

The settings are saved.

Displaying the clock time continuously

You can make the system display the clock time when the device is off and the vehicle ignition is on.

- ⇨ Press the **MENU** button (9).
- ⇨ Press the softkey (5) assigned to the "CLOCK" display item.
- ⇨ Press the softkey (5) assigned to the "OFFCLOCK" display item.

"SHOW CLOCK" means that the clock time will be displayed; "HIDE CLOCK" means it will not be displayed.

DSA Max - Digital Sound Adjustment

This device is equipped with a digital sound calibration feature (DSA - Digital Sound Adjustment).

It provides you with three self-calibrating user equalizers (EQ1, EQ2 and EQ3). Each user equalizer consists of a 27-band graphic equalizer.

Each user equalizer has four channels (front right/left and rear right/left) at its disposal. The EQ1 - EQ3 equalizers can be calibrated automatically with the help of the calibration microphone (included). You can also manually adjust the automatically ascertained values of the graphic equalizer.

In addition, you can also optimise the sound using a dynamic vehicle noise cover-up feature (DNC), various presets for different music styles (Preset EQ), stage effects and sound effects.

Switching DSA on/off

Switching DSA off

To switch off the entire equalizer,

- ⇨ press and hold down the **AUDIO** button (10) for longer than two seconds.

The DSA menu appears in the display.

- ⇨ Press the softkey (5) assigned to the "OFF" display item.

"DSA OFF" appears in the display.

Note:

- You can activate/deactivate each equalizer module individually (user EQ, sound presets, DNC, stage effects and sound effects) in the corresponding menu.

Switching on DSA

To switch the equalizer on again,

- ⇒ press and hold down the **AUDIO** button (10) for longer than two seconds.

The DSA menu appears in the display.

- ⇒ Press the softkey (5) assigned to the “USER EQ” display item.
- ⇒ Select an equalizer setting.

Automatically calibrating the equalizer

You can electronically calibrate and store values for three different situations, e.g.:

- EQ 1** for the driver only
- EQ 2** for the driver and front passenger
- EQ 3** for the front and rear occupants

Hold the microphone in the appropriate position whilst calibration is taking place.

The position of the calibration microphone for Situation 1 (e.g. for the driver alone) is at the height of the driver's head, approx. 10 cm next to the right ear.

For Situation 2, the calibration microphone should be positioned at head height between the driver and the front passenger.

For Situation 3, you should position the calibration microphone at head height in the centre of the vehicle interior (left/right, front/rear).

Really quiet surroundings are required for the calibration. Any extraneous noise will distort the measured values. The windows, doors and sunroof must remain closed during the calibration process. You should be seated in the driving seat throughout this procedure.

Note:

- The sound radiating from the loudspeakers must not be obstructed by any objects. All the loudspeakers must be connected. The calibration microphone must be connected to the device, and equalizer calibration should be carried out before DNC calibration.

To calibrate an equalizer,

- ⇒ press and hold down the **AUDIO** button (10) for longer than two seconds.
- ⇒ Press the softkey (5) assigned to the “USER EQ” display item.
- ⇒ Press the softkey (5) assigned to the display item of the equalizer (“EQ-1”, “EQ-2” or “EQ-3”) that you want to calibrate.
- ⇒ Press the softkey (5) assigned to the “ADJUST” display item.
- ⇒ Press the softkey (5) assigned to the “AUTO ADJ” display item.

A countdown starts in the display. You have the opportunity to position the calibration microphone during this time

DSA MAX EQUALIZER

period. Calibration begins as soon as the countdown is finished.

- ⇒ Proceed as described for all the equalizers.

When calibration has ended, the menu for the selected equalizer is displayed again.

Viewing the vehicle acoustics with/without equalization

You can view the ascertained values for the vehicle acoustics. When viewing the settings, you can choose between the equalizer view without equalization ("PRE EQ") or with equalization ("POST EQ").

- ⇒ Press and hold down the **AUDIO** button (10) for longer than two seconds.
- ⇒ Press the softkey (5) assigned to the "USER EQ" display item.
- ⇒ Press the softkey (5) assigned to the display item of the equalizer that you want to view.
- ⇒ Press the softkey (5) assigned to the "ADJUST" display item.
- ⇒ Press the softkey (5) assigned to the "MANUAL" display item.

You can view the equalizer settings for the front and rear loudspeakers separately.

Note:

- If you have already adjusted the graphic equalizer manually or if you have not carried out any calibration yet, you will not be able to select

any of the softkeys that are described below.

If you want to select the equalizer view **without** equalization,

- ⇒ press the softkey (5) assigned to the "VIEW PRE" display item on the left of the display for the front or on the right of the display for the rear.

The equalizer setting is displayed.

If you want to select the equalizer view **with** equalization,

- ⇒ press the softkey (5) assigned to the "VIEWPOST" display item on the left of the display for the front or on the right of the display for the rear.

The equalizer setting is displayed.

To close the view,

- ⇒ press the joystick **OK** (8) or the **AUDIO** button (10).

Adjusting the graphic equalizer manually

You can also manually adjust the automatically ascertained values of the graphic equalizer.

- ⇒ Press and hold down the **AUDIO** button (10) for longer than two seconds.
- ⇒ Press the softkey (5) assigned to the "USER EQ" display item.
- ⇒ Press the softkey (5) assigned to the display item of the equalizer that you want to set up.

- ⇒ Press the softkey (5) assigned to the “ADJUST” display item.
- ⇒ Press the softkey (5) assigned to the “MANUAL” display item.

You can adjust the equalizer for the front and rear loudspeakers separately.

- ⇒ Press the softkey (5) assigned to the “FRONT EQ” display item for the front loudspeakers or “REAR EQ” for the rear loudspeakers.

The graphic equalizer settings are displayed.

To select the frequency,

- ⇒ repeatedly press the joystick (8) left or right until the frequency that you want is displayed.
- ⇒ Adjust the gain for the frequency by moving the joystick (8) up or down.

The values appear graphically in the display whilst you are adjusting the equalizer.

- ⇒ Adjust all the settings for both channels as described earlier on.
- ⇒ Press the joystick **OK** (8) or the **AUDIO** button (10) to close the menu.

The settings are saved.

Selecting an equalizer

After calibration has taken place or after you have finished making manual adjustments,

- ⇒ press and hold down the **AUDIO** button (10) for longer than two seconds.

- ⇒ Press the softkey (5) assigned to the “USER EQ” display item.
- ⇒ Press the softkey (5) assigned to the display item of the equalizer that you want to use.
- ⇒ Press the joystick **OK** (8) or the **AUDIO** button (10) to close the menu.

The settings are saved.

Resetting the equalizer

You can reset all the automatically ascertained values of the selected equalizer.

- ⇒ Press and hold down the **AUDIO** button (10) for longer than two seconds.
- ⇒ Press the softkey (5) assigned to the “USER EQ” display item.
- ⇒ Press the softkey (5) assigned to the display item of the equalizer that you want to reset.
- ⇒ Press the softkey (5) assigned to the “ADJUST” display item.
- ⇒ Press and hold down the softkey (5) assigned to the “CLEAR” display item for longer than two seconds.

The automatically ascertained values of the equalizer are cleared.

- ⇒ Press the joystick **OK** (8) or the **AUDIO** button (10) to close the menu.

The settings are saved.

DSA MAX EQUALIZER

Selecting sound presets

You can select sound presets for various music styles. To ensure optimum sound, the presets are “added” to the settings of the active user equalizer, i.e. the user EQs are optimised using the presets for the various music styles.

Presets for the following music styles are available:

- VOCAL
- DISCO
- ROCK
- JAZZ
- CLASSIC

The settings for these music styles have already been programmed.

- ⇨ Press and hold down the **AUDIO** button (10) for longer than two seconds.
- ⇨ Press the softkey (5) assigned to the “PRESET” display item.
- ⇨ Press the softkey (5) assigned to the display item of the sound preset that you want to use.
- ⇨ Press the joystick **OK** (8) or the **AUDIO** button (10) to close the menu.

The settings are saved.

Setting the stage effect

You can activate a stage effect that “repositions” the music in front of the driver and/or front passenger. This gives you the impression you are standing directly in front of a stage. You can set the distance to your loudspeakers in order to optimise this effect.

Selecting a stage effect

- ⇨ Press and hold down the **AUDIO** button (10) for longer than two seconds.
- ⇨ Press the softkey (5) assigned to the “STAGING” display item.
- ⇨ Press the softkey (5) assigned to the “LEFT” display item for a stage effect for the driver.
- ⇨ Press the softkey (5) assigned to the “RIGHT” display item for a stage effect for the front passenger.
- ⇨ Press the softkey (5) assigned to the “FRONT” display item for a stage effect for the driver and front passenger.
- ⇨ Press the joystick **OK** (8) or the **AUDIO** button (10) to close the menu.

The settings are saved.

Setting the distance of the loudspeakers

To further optimise the stage effect, you can set the distance of the in-car loudspeakers relative to the front left seat. You can set the distance to the front loudspeakers between 0-200 cm and the distance to the rear loudspeakers between 0-400 cm.

- ⇨ Select the stage effect as described earlier on.
- ⇨ Press the **NEXT** button (4).
- ⇨ Select the softkey assigned to the loudspeaker whose distance setting you want to set. “RR” is right rear, “LR” is left rear, “RF” is right front and “LF” is left front.

- ⇨ Turn the volume control (2) or move the joystick (8) to adjust the distance.
- ⇨ Proceed in the same way for all the loudspeakers and press the joystick **OK** (8) or the **AUDIO** button (10) to close the menu.

The settings are saved.

Selecting the sound effect

You can choose between different sound effects for your music:

- CATHEDRAL
- THEATER
- CONCERT
- CLUB
- STADIUM

These sound effects have already been programmed.

- ⇨ Press and hold down the **AUDIO** button (10) for longer than two seconds.
- ⇨ Press the softkey (5) assigned to the “EFFECTS” display item.
- ⇨ Press the softkey (5) assigned to the display item of the sound effect that you want to use.

If you do not want to use any sound effects,

- ⇨ press the softkey (5) assigned to the “OFF” display item.
- ⇨ Press the joystick **OK** (8) or the **AUDIO** button (10) to close the menu.

The settings are saved.

DNC - Dynamic Noise Covering

The **Dynamic Noise Covering** feature increases the volume whilst the vehicle is driving. As its starting point it uses a volume level that is considered pleasant whilst the vehicle is stationary.

The volume is boosted by a different amount for each frequency band depending on how noise develops in the vehicle.

This ensures that the volume level and sound characteristics can still be appreciated even if noise in the vehicle varies. Noises that only last a short time, such as when crossing railway tracks, are not taken into account.

Calibrating DNC

In order for this feature to work properly for your vehicle, you must calibrate it using the calibration microphone. Please carry out the DNC calibration after the DSA calibration. **Before** carrying out the calibration, you should permanently attach the calibration microphone near the console using the supplied Velcro tape. However, do not place it in the footwell, near locations where booming sounds can be heard or near the ventilation/heating.

The calibration microphone’s opening must point towards the passenger compartment. Calibration should be carried out in a quiet location whilst the engine is switched off. Keep the doors, windows and sunroof closed, and sit yourself in the driver’s seat whilst calibration is taking place.

Starting DNC calibration

- ⇨ Press and hold down the **AUDIO** button (10) for longer than two seconds.
- ⇨ Press the softkey (5) assigned to the “DNC” display item.
- ⇨ Press the softkey (5) assigned to the “ADJUST” display item.

A countdown starts in the display. Calibration begins as soon as the countdown is finished.

- ⇨ Press the joystick **OK** (8) or the **AUDIO** button (10) to close the menu.

Switching off DNC

To switch off DNC,

- ⇨ Press and hold down the **AUDIO** button (10) for longer than two seconds.
- ⇨ Press the softkey (5) assigned to the “DNC” display item.
- ⇨ Press the softkey (5) assigned to the “OFF” display item.

“DNC OFF” appears in the display.

To switch DNC on again,

- ⇨ select a DNC boost level (DNC1 - DNC5).
- ⇨ Press the joystick **OK** (8) or the **AUDIO** button (10) to close the menu.

The settings are saved.

Selecting the DNC boost

You can select the DNC boost (i.e. the sensitivity of the volume and sound boost) to five levels.

The “DNC 1” setting is suitable for vehicles with a loud engine and music with a lot of bass. The “DNC 5” setting is suitable for vehicles with a quiet engine and for classical music. Find out the best setting for your situation by trying out the various settings.

To select a DNC boost level,

- ⇨ press and hold down the **AUDIO** button (10) for longer than two seconds.
- ⇨ Press the softkey (5) assigned to the “DNC” display item.
- ⇨ Press the softkey (5) assigned to the “LEVEL” display item.
- ⇨ Set the boost level using the joystick (8).
- ⇨ Press the joystick **OK** (8) or the **AUDIO** button (10) to close the menu.

The settings are saved.

Subwoofer and centre speaker

You can connect a subwoofer and a centre speaker to this device.

In order to optimise the sound still further when using a subwoofer and centre speaker, you can set a low-pass filter for the subwoofer and a high-pass filter for the front and rear channels separately.

Adjusting the subwoofer boost level (gain)

You can set a permanent volume boost/reduction level between -6 and +6 for the connected subwoofer and therefore emphasise or tone down the subwoofer's bass reproduction. The setting that you should select depends on the installation position and location of the subwoofer in your vehicle. If necessary, find out which setting you prefer by trying out the various settings.

- ⇒ Press the **AUDIO** button (10).

"AUDIO MENU" appears in the display.

- ⇒ Press the softkey (5) assigned to the "SUBOUT" display item.

- ⇒ Press the softkey (5) assigned to the "GAIN" display item.

- ⇒ Move the joystick (8) up/right to boost the gain or move it down/left to reduce the gain.

When you have finished making your changes,

- ⇒ press the joystick **OK** (8) or the **AUDIO** button (10).

Adjusting the subwoofer phase

You can adjust the phase of the subwoofer output to suit your subwoofer. The phase setting can be adjusted in steps of "45°" to between "-135°" and "180°".

- ⇒ Press the **AUDIO** button (10).

"AUDIO MENU" appears in the display.

- ⇒ Press the softkey (5) assigned to the "SUBOUT" display item.

- ⇒ Press the softkey (5) assigned to the "PHASE" display item.

- ⇒ Move the joystick (8) to switch between the available settings.

When you have finished making your changes,

- ⇒ press the joystick **OK** (8) or the **AUDIO** button (10).

Setting up the low-pass filter

You can use the low-pass filter to set a frequency up to which the subwoofer will work. All the signals above the set frequency will be "cut off" and not sent to the subwoofer.

You can choose between the following frequencies: "40 Hz", "50 Hz", "63 Hz" and "100 Hz". If your subwoofer is fitted with a built-in low-pass filter, you can also select the "FLAT" setting and thus allow all the frequencies to be sent to the subwoofer.

You should adjust this setting to suit the frequency range and capabilities of your subwoofer. For further information, please read the subwoofer's documentation.

SUBWOOFER AND CENTRE SPEAKER

- ⇒ Press the **AUDIO** button (10).
“AUDIO MENU” appears in the display.
- ⇒ Press the softkey (5) assigned to the “SUBOUT” display item.
- ⇒ Press the softkey (5) assigned to the “LOWPASS” display item.
- ⇒ Move the joystick (8) to switch between the available settings.

When you have finished making your changes,

- ⇒ press the joystick **OK** (8) or the **AUDIO** button (10).

Setting up the subsonic filter

To avoid interference due to extremely low frequencies, you can set the subsonic filter to limit the frequency response of the device at the lower end of the range. This makes particularly good sense if you are using a small subwoofer. If you set up the subsonic filter, all the frequencies below the set frequency will be suppressed. When setting up the subsonic filter, you should base the settings that you choose on the specifications of the loudspeakers in your vehicle.

The following frequencies are available: “20 Hz”, “25 Hz”, “32 Hz” and “40 Hz”.

You can also set a quality factor “Q” in five steps for the selected frequency: “Q1”=0.5, “Q2”=0.7, “Q3”=0.9, “Q4”=1.1 and “Q5”=1.3.

If you select the “FLAT” setting, the frequency response of the device will not be modified.

- ⇒ Press the **AUDIO** button (10).
“AUDIO MENU” appears in the display.
- ⇒ Press the softkey (5) assigned to the “SUBOUT” display item.
- ⇒ Press the softkey (5) assigned to the “SUBSONIC” display item.
- ⇒ Move the joystick (8) left or right to choose between the available frequencies.
- ⇒ Move the joystick (8) up or down to select the quality factor that you want for the set frequency.

You can use the quality factor to adjust the width of the filter. The higher you set the value for the quality factor the more directly the filter will be applied to the selected frequency.

When you have finished making your changes,

- ⇒ press the joystick **OK** (8) or the **AUDIO** button (10).

Setting up the centre speaker

You can select the frequency above which you want a connected centre speaker to be driven.

The following frequencies are available: “200 Hz”, “400 Hz”, “800 Hz”, “1600 Hz” and “3200 Hz”. If you select the “FLAT” setting, all the frequencies (including the bass) will be reproduced by the centre speaker. You should only select this setting if your centre speaker has a built-in high-pass filter.

Besides the frequency, you can also adjust the gain for the centre speaker.

SUBWOOFER AND CENTRE SPEAKER

- ⇒ Press the **AUDIO** button (10).
“AUDIO MENU” appears in the display.
- ⇒ Press the **NEXT** button (4).
“AUDIO MENU 2” appears in the display.
- ⇒ Press the softkey (5) assigned to the “CENTRE” display item.
- ⇒ Press the joystick (8) left or right to set the frequency for the centre speaker.
- ⇒ Press the joystick (8) up or down to set the gain for the centre speaker.

When you have finished making your changes,

- ⇒ press the joystick **OK** (8) or the **AUDIO** button (10).

Setting up the high-pass filter for the front/rear channels

You can set up a high-pass filter separately for the front and rear channels. The high-pass filter will filter out all of the frequencies below the frequency that you set, thus ensuring that the filtered frequencies are only reproduced by a connected subwoofer.

If you select the “FLAT” setting, none of the frequencies will be filtered out thus ensuring that all of the signals are sent to the loudspeakers. If you select the “AUTO” setting, the high-pass filter will automatically be adjusted to suit the value that you set for the low-pass filter.

- ⇒ Press the **AUDIO** button (10).
“AUDIO MENU” appears in the display.
- ⇒ Press the **NEXT** button (4).
“AUDIO MENU 2” appears in the display.
- ⇒ Press the softkey (5) assigned to the “HIPASS F” display item in order to set up the high-pass filter for the front.

or

- ⇒ Press the softkey (5) assigned to the “HIPASS R” display item in order to set up the high-pass filter for the rear.
- ⇒ Press the joystick (8) left or right to set the frequency for the high-pass filter.

When you have finished making your changes,

- ⇒ press the joystick **OK** (8) or the **AUDIO** button (10).

Amplifier/sub-out

The car sound system provides connections that allow you to connect external amplifiers. You can also connect a subwoofer to the device's integrated low-pass filter. In order for this to work, the amplifier and subwoofer must be connected in the manner described in the installation instructions. We recommend you use well-matched products from the Blaupunkt or Velocity product ranges.

Switching the internal amplifier on/off

If you use external amplifiers, you can switch off the device's internal amplifier ("INTERNAL AMP OFF" setting).

Note:

- Please check this setting if the loudspeakers do not emit any sound.
- ⇒ Press the **MENU** button (9).
- ⇒ Press the softkey (5) assigned to the "VARIOUS" display item.
- ⇒ Repeatedly press the softkey (5) assigned to the "AMP ON" display item until the "INTERNAL AMP ON" or "INTERNAL AMP OFF" setting that you want is displayed. The "AMP ON" softkey will be displayed with a dark background if the internal amplifier is switched on.
- ⇒ Press the joystick **OK** (8) or the **MENU** button (9) to close the menu.

The settings are saved.

External audio sources

You can connect up to two external audio sources to the device. Audio sources can, for example, be portable CD players, MiniDisc players or MP3 players.

You can connect the first external audio source (AUX1) **instead** of a CD changer.

You can connect the second external audio source (AUX2) **in addition** to the CD changer or AUX1.

Instead of AUX2, you can connect a navigation system. For further information, please read the section entitled "Navigation audio" in the "Adjusting the volume" chapter.

In order to be able to use the AUX inputs, you must activate them in the set-up menu.

If you want to connect an external audio source, you will need an adapter cable. You can obtain this cable from a Blaupunkt dealer.

Switching the AUX input on/off

- ⇒ Press the **MENU** button (9).
- ⇒ Press the softkey (5) assigned to the "AUX" display item.

The AUX menu is displayed.

- ⇒ Press the softkey (5) assigned to the "AUX1" display item if no CD changer is connected and you want to connect an external audio source.

By pressing the “AUX1” softkey you can switch between the “AUXILIARY 1 ON” and “AUXILIARY 1 OFF” settings.

- ⇒ Press the softkey (5) assigned to the “NAV/AUX2” display item if no navigation system is connected and you want to connect an external audio source. By pressing the “NAV/AUX2” softkey you can switch between the “AUXILIARY 2 ON” and “NAVIGATION ON” settings.

Note:

- If a CD changer is connected, you cannot change the “AUX1” input.
- ⇒ Press the joystick **OK** (8) or the **MENU** button (9) to close the menu.

The settings are saved.

Note:

- If the AUX inputs are activated, you can select them by pressing the **SOURCE** button (12).

Naming the AUX input

You can give each AUX input a name so you can recognise them more easily when selecting them using the **SOURCE** button (12) (e.g. you can give them the device names that they are connected to).

- ⇒ Press the **MENU** button (9).
- ⇒ Press the softkey (5) assigned to the “AUX” display item.

The AUX menu is displayed.

- ⇒ Press the softkey (5) assigned to the “EDIT” display item under “AUX1” or “NAV/AUX2”.

The default text for the selected input appears in the display. The text input marker flashes at the beginning of the line.

To enter a name,

- ⇒ press the joystick (8) to the left or right to move the input marker.
- ⇒ Enter the letter that you want by pressing the joystick (8) up or down.
- ⇒ Once you have finished entering the name, press the joystick **OK** (8) or the **MENU** button (9) to close the menu.

The settings are saved.

Entering the power-on message

After you switch on your device, the system displays a scrolling message in the display. The factory default for this text is "BLAUPUNKT-THE ADVANTAGE IN YOUR CAR". Instead of this you can enter your own text up to 35 characters long.

- ⇒ Press the **MENU** button (9).
- ⇒ Press the softkey (5) assigned to the "VARIOUS" display item.
- ⇒ Press the softkey (5) assigned to the "ON MSG" display item.

The default text for the power-on message appears in the display. The text input marker flashes at the beginning of the line.

To enter a different text,

- ⇒ press the joystick (8) to the left or right to move the input marker.
- ⇒ Enter the letter that you want by pressing the joystick (8) up or down.
- ⇒ Once you have finished entering the message, press the joystick **OK** (8) or the **MENU** button (9) to close the menu.

The settings are saved.

Displaying the serial number

You can display the device's serial number.

- ⇒ Press the **MENU** button (9).
- ⇒ Press the softkey (5) assigned to the "VARIOUS" display item.
- ⇒ Press the softkey (5) assigned to the "SER NUM" display item.

The device's serial number will be displayed in the top line of the display.

- ⇒ Press the joystick **OK** (8) or the **MENU** button (9) to close the menu.

Resetting the device

You can reset the device to its factory default settings. All custom settings will then be cleared.

- ⇨ Press the **MENU** button (9).
- ⇨ Press the softkey (5) assigned to the "VARIOUS" display item.
- ⇨ Press and hold down the softkey (5) assigned to the "NORMSET" display item for longer than two seconds.

The device will switch off and then back on again automatically.

Specifications

Amplifier

Output power: 4 x 18 watts sine at 14.4 V and 1% distortion factor at 4 ohms.
4 x 26 watts sine in accordance with DIN 45324 at 14.4 V at 4 ohms.
4 x 50 watts max. power

Tuner

Wavebands:
FM : 87.7 – 107.9 MHz
AM : 530 – 1 710 kHz
SW : 5.85 – 6.30 MHz (49 m band)

FM frequency response:
20 - 16,000 Hz

CD

Frequency response:
15 - 20,000 Hz

Pre-amp out

4 channels: 4 V / < 1 kΩ

AUX input

Input sensitivity: 1.2 V / 10 kΩ

Subject to changes!

Service numbers / Numéros du service après-vente / Números de servicio / Número de serviço

Country:	Phone:	Fax:	WWW:
Germany	(D) 0180-5000225	05121-49 4002	http://www.blaupunkt.com
Austria	(A) 01-610 390	01-610 393 91	
Belgium	(B) 02-525 5444	02-525 5263	
Denmark	(DK) 44 898 360	44-898 644	
Finland	(FIN) 09-435 991	09-435 99236	
France	(F) 01-4010 7007	01-4010 7320	
Great Britain	(GB) 01-89583 8880	01-89583 8394	
Greece	(GR) 0030-210 94 27 337	0030-210 94 12 711	
Ireland	(IRL) 01-4149400	01-4598830	
Italy	(I) 02-369 62331	02-369 62464	
Luxembourg	(L) 40 4078	40 2085	
Netherlands	(NL) 023-565 6348	023-565 6331	
Norway	(N) 66-817 000	66-817 157	
Portugal	(P) 01-2185 00144	01-2185 11111	
Spain	(E) 902-120234	916-467952	
Sweden	(S) 08-7501500	08-7501810	
Switzerland	(CH) 01-8471644	01-8471650	
Czech. Rep.	(CZ) 02-6130 0441	02-6130 0514	
Hungary	(H) 01-333 9575	01-324 8756	
Poland	(PL) 0800-118922	022-8771260	
Turkey	(TR) 0212-3350677	0212-3460040	
USA	(USA) 800-2662528	708-6817188	
Brasil (Mercosur)	(BR) +55-19 3745 2769	+55-19 3745 2773	
Malaysia (Asia Pacific)	(MAL) +604-6382 474	+604-6413 640	

Blaupunkt GmbH

