



RFP-1208

RFP-1210

RFP-1212

RFP-1215

punch



Dear Customer,

Congratulations on your purchase of the world's finest brand of car audio speakers. At Rockford Fosgate we are fanatics about musical reproduction at its best, and we are pleased you chose our product. Through years of engineering expertise, hand craftsmanship and critical testing procedures, we have created a wide range of products that reproduce music with all the clarity and richness you deserve.

For maximum performance we recommend you have your new Rockford Fosgate product installed by an Authorized Rockford Fosgate Dealer, as we provide specialized training through Rockford Technical Training Institute (RTTI). Please read your warranty and retain your receipt and original carton for possible future use.

Great product and competent installations are only a piece of the puzzle when it comes to your system. Make sure that your installer is using 100% authentic installation accessories from Connecting Punch in your installation. Connecting Punch has everything from RCA cables and speaker wire to Power line and battery connectors. Insist on it! After all, your new system deserves nothing but the best.

To add the finishing touch to your new Rockford Fosgate image order your Rockford wearables, which include everything from T-shirts and jackets to hats and sunglasses.

To get a free brochure on Rockford Fosgate products and Rockford wearables, in the U.S. call 602-967-3565 or FAX 602-967-8132. For all other countries, call +001-602-967-3565 or FAX +001-602-967-8132.

PRACTICE SAFE SOUND™

CONTINUOUS EXPOSURE TO SOUND PRESSURE LEVELS OVER 100dB MAY CAUSE PERMANENT HEARING LOSS. HIGH POWERED AUTOSOUND SYSTEMS MAY PRODUCE SOUND PRESSURE LEVELS WELL OVER 130dB. USE COMMON SENSE AND PRACTICE SAFE SOUND.

If, after reading your manual, you still have questions regarding this product, we recommend that you see your Rockford Fosgate dealer. If you need further assistance, you can call us direct at 1-800-795-2385. Be sure to have your serial number, model number and date of purchase available when you call.

The serial number can be found on the outside of the box. Please record it in the space provided below as your permanent record. This will serve as verification of your factory warranty and may become useful in recovering your speaker if it is ever stolen.

Serial Number: _____

Model Number: _____

TABLE OF CONTENTS

Introduction	1
DVC Woofer Contents	1
Technical Design Features	1
Installation	4
Recommended Enclosures	4
Building an Enclosure	6
Calculating Volume	6
Subwoofer Crossovers	6
Wiring Configurations	7
Specifications	8
Warranty Information	9
International Information	10

GETTING STARTED

Welcome to Rockford Fosgate! This manual is designed to provide information for the owner, salesperson and installer. For those of you who want quick information on how to install this product, please turn to the ***Installation Section*** of this manual or refer to the icon listed below. Other information can be located by using the Table of Contents. We, at Rockford Fosgate, have worked very hard to make sure all the information in this manual is current. But, as we are constantly finding new ways to improve our product, this information is subject to change without notice.



Sections marked
INSTALLATION
include "slam dunk"
assembly and wiring
directions

INTRODUCTION

The Punch Dual Voice Coil woofers are low frequency drivers designed primarily for use in **small, sealed or vented enclosures**. The dual voice coil design allows low impedance loads to be configured for optimizing the performance of Punch Power 50.1 and 50.2 amplifiers. By utilizing the latest materials and construction techniques, we are able to offer a speaker with optimized low frequency response while requiring a minimum of operating space.

DVC WOOFER CONTENTS

Punch DVC Woofer
Installation & Owner's Manual

TECHNICAL DESIGN FEATURES

◆ Stamped Basket

The Dual Voice Coil Woofers use a stamped Cold Rolled Steel basket which is rigid and lightweight. The basket is finished in a corrosive resistant power coated applied process used in many automotive applications.

THE RESULT: A lightweight and rigid woofer.

◆ PVA Cone

The cone material used is spruce pulp paper. This provides the necessary combination of weight and strength and allows high levels of output without cone break-up. The cone is treated with a water resistant **PolyVinyl Acetate (PVA) Emulsion** which increases the cone rigidity and lowers distortion.

THE RESULT: Increases cone rigidity and lowers distortion.

◆ Santoprene Rubber Surround

The santoprene material is resilient to temperature variations and provides a consistent support necessary for the linear motion of the speaker cone. In addition, the inherent damping capabilities eliminates the transmission of sonic disturbances between the cone and the frame of the speaker. This greatly improves the clarity of the speaker's frequency response.

THE RESULT: Improves speaker's frequency response.

◆ Flat Spider

The speaker's linear compliance is balanced through the use of a "proprietary" flat spider design. A flat spider provides symmetrical control of the voice coil through its cone excursion. Linear cone excursion reduces harmonic distortion for improved sound quality.

THE RESULT: Reduces mechanical distortion for better sound quality.

◆ Powder Coat Finish

Powder coating has long been the industry standard for durability in protective metal finishes. A dry powder (non-aerosol) is electrostatically applied to the metal and "baked on to provide a hard "shell-like" finish. As an additional benefit, powder coating is the only finishing process that releases no toxic chemicals into our ozone.

THE RESULT: A durable and "earth friendly" metal finish.

◆ Inverted Dust Cap

The use of the inverted dust cap serves to increase the cone rigidity and improve the power handling by forcing more air through the voice coil.

THE RESULT: Increases cone rigidity, smooths frequency response and prevents your friends from feeling obligated to invert them for you.

◆ Aluminum Voice Coil Former

The voice coil former is black, anodized aluminum for highly efficient thermal transfer. This allows winding high temperature copper wire in multiple layers for improved efficiency.

THE RESULT: Improves power handling by efficiently dissipating heat.

◆ Hyper-Extended Pole Piece

The pole piece has been extended to provide a more linear magnetic field for the operation of the woofer. This lowers distortion and provides the woofer with better low frequency response.

THE RESULT: Lowers distortion and provides better low frequency response.

◆ Vented Bumped Back Plate

The back plate has been stepped deeper to allow the woofer more excursion without bottoming out. This enables the speaker to be used in a smaller enclosure. Additionally, the back plate is vented with a radiused aerodynamic back vent which efficiently and quietly circulates cool air around the voice coil.

THE RESULT: More excursion and increased power handling.

◆ Dual Voice Coils

The dual voice coil design of the speaker allows a variety of impedance loads to be configured. A single woofer can be wired for a 2Ω load and a pair of woofers can be wired for either a 4Ω or 1Ω load. These configurations allow a multitude of amplifiers to be used with the Punch DVC.

THE RESULT: Allows multiple wiring configurations.

INSTALLATION

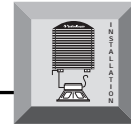

Recommended Enclosures Punch DVC 8"

Recommended Sealed .30ft³ (8.50L)

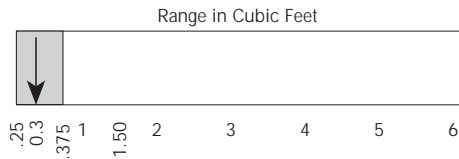
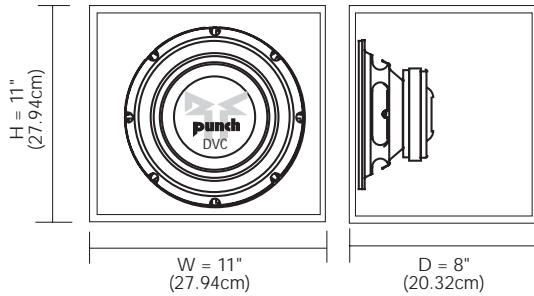

Recommended Ported .625ft³ (17.70L)

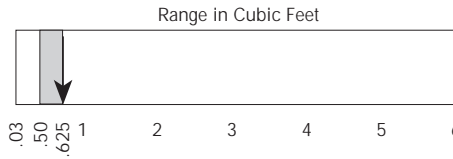
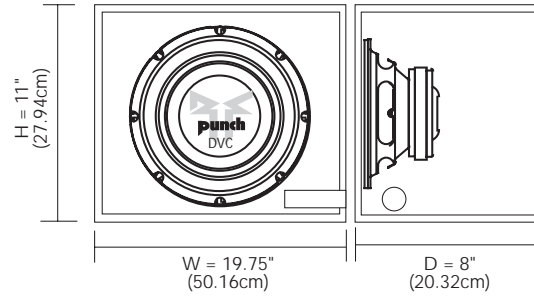

Fb=35Hz
Pd=2.5" (6.35cm)
PI=15.25" (38.73cm)

Punch DVC 10"

Recommended Sealed .625ft³ (17.70L)

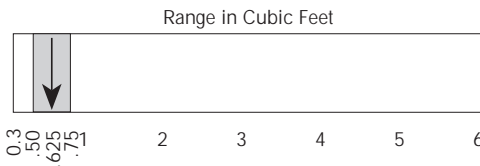
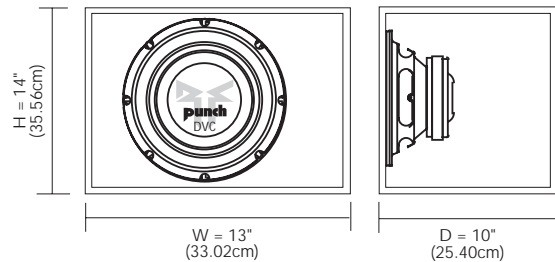

Recommended Ported 1.0ft³ (28.32L)

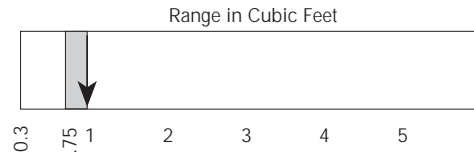
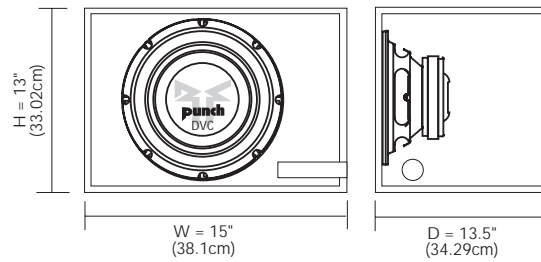

Fb=35Hz
Pd=3" (7.62cm)
PI=13.25" (33.65cm)

Fb = Tuning Frequency

Pd = Inside Port Diameter

PI = Total Port Length

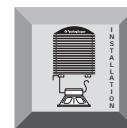

Punch DVC 12"

Recommended Sealed 1.25ft³ (35.40L)

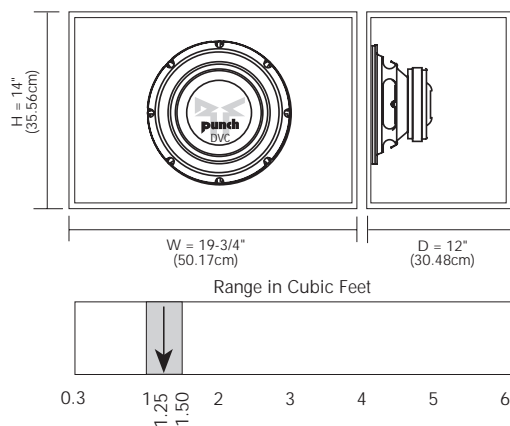

Recommended Ported 2.0ft³ (56.63L)

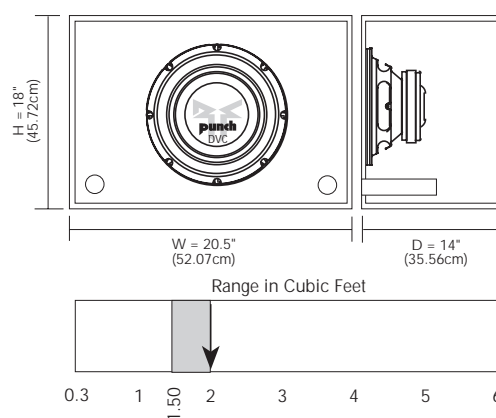

Fb=30Hz
Pd=2 x 2.5" (2 x 6.35cm)
PI=12" (30.48cm)

Punch DVC 15"

Recommended Sealed 1.5ft³ (42.47L)

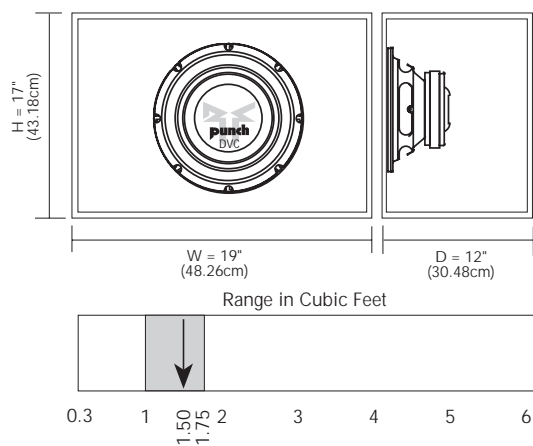

Recommended Ported 2.25ft³ (63.71L)

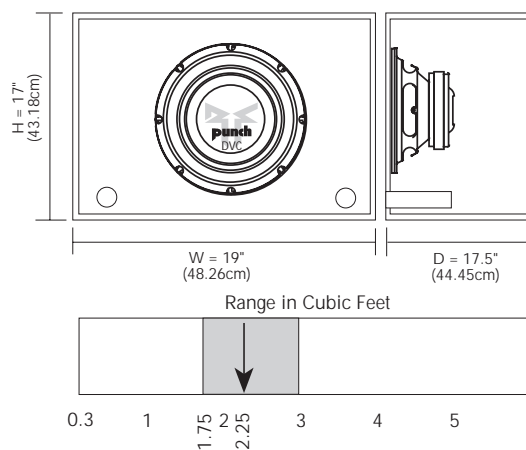

Fb=30Hz
Pd=2 x 3" (2 x 7.62cm)
PI=15.5" (39.37cm)

Fb = Tuning Frequency

Pd = Inside Port Diameter

PI = Total Port Length

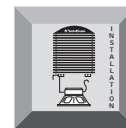

Building an Enclosure

To work properly, the walls of the enclosure must be rigid and not flex when subjected to the high pressures generated by the speaker's operation. For optimum performance, we recommend using 3/4" MDF (Medium Density Fiberboard) and internal bracing. The enclosure should be glued together with nails or screws. Because MDF is porous, it is suggested to seal the outside walls with polyurethane.

Calculating Volume

Calculating volume is merely a matter of measuring the dimensions in inches and using the formula:

$$\text{Box Volume} = \frac{\text{Height} \times \text{Width} \times \text{Depth}}{1728"} \\ \text{(cubic feet)}$$

If two facing sides are of uneven length, add them together and divide by two to take the average. Using this number will give you the volume without the necessity of calculating the box in sections and adding the sections together. The thickness of the baffle material reduces the internal volume so this must be subtracted from the outside dimensions to determine the internal volume. The speaker itself also reduces the internal volume. The amount of air displaced by each model is listed on the specification sheet and should also be subtracted from the gross volume calculation.

Subwoofer Crossovers

There are two operational types of crossovers, passive and active. Passive crossovers (coils or inductors) are placed on the speaker leads between the amplifier and speaker. An active crossover is an electronic filter which separates the audio signal fed to different amplifiers. *For optimum subwoofer performance, we recommend using an active 80-100Hz low-pass crossover at 12dB/octave.*

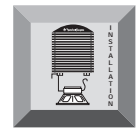

Wiring Configurations

Three configurations for connecting speakers to an amplifier are **Series**, **Parallel**, and **Series-Parallel** wiring. A Series configuration consists of two or more speakers (voice coil) wired in a string (end to end). A Parallel configuration consists of two or more speakers (voice coils) wired with the common terminals connected across each other. A Series-Parallel configuration is a combination of both methods. Determine which method will be compatible with your amplifier.

Series Wiring

$$R_T = R_1 + R_2 + R_3 + \text{etc.}$$

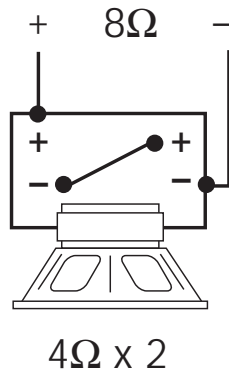

Parallel Wiring

$$\frac{1}{R_T} = \frac{1}{R_1} + \frac{1}{R_2} + \frac{1}{R_3} + \frac{1}{R_4} + \text{etc.}$$

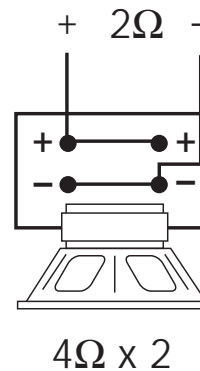

Series/Parallel Wiring

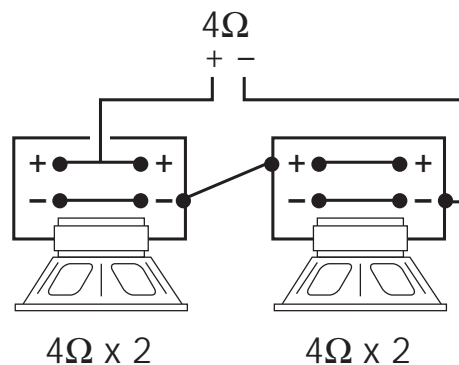
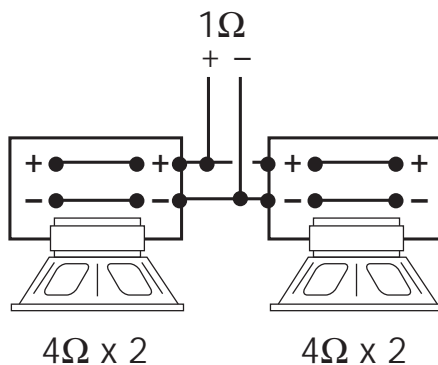

- R_T indicates the total speaker load
- $R_1, R_2, \text{etc.}$ indicates each speaker in the system
- **Purple dot** indicates "+" terminal of 4 ohm speaker

SPECIFICATIONS

Model	RFP-1208	RFP-1210	RFP-1212	RFP-1215
Nom. Imped.	2 x 4Ω	2 x 4Ω	2 x 4Ω	2 x 4Ω
FS (Hz)	40	30	25	21
RE (Ohm)	2 x 3.6	2 x 3.3	2 x 3.3	2 x 4.0
LE (mH)	1.2	1.12	1.12	3.53
QMS	5.13	5.06	5.40	6.81
QES	0.38	0.37	0.45	0.35
QTS	0.36	0.34	0.42	0.33
VAS (cu.ft)	0.55	1.44	3.67	8.79
VAS (liter)	15.5	40.7	103.9	249
Power (Watts RMS)	250	400	400	500
Power (Watts Peak)	500	800	800	1000
SPL (dB @ 1w/1m)	85	86	88	90
X-MAX (inches)	0.41	0.44	0.44	0.44
X-MAX (mm)	10.3	11.2	11.2	11.2
Speaker Disp. (cu. ft.)	.035	.06	.085	.135
Mntg. Dia. (in.)	7 ¹ / ₁₆ "	9 ⁵ / ₁₆ "	11 ¹ / ₁₆ "	13 ¹⁵ / ₁₆ "
Mntg. Depth (in.)	4 ¹ / ₂ "	5 ¹⁵ / ₃₂ "	6 ⁷ / ₃₂ "	7 ¹³ / ₃₂ "

Thiele-Small data measured with both voice coils wired in parallel.

Specifications are subject to change without notice.

LIMITED WARRANTY INFORMATION

Rockford Corporation offers a limited warranty on Rockford Fosgate products on the following terms:

- **Length of Warranty**

1 year on speakers	30 days on speaker B-stock (receipt required)
3 years on electronics	90 days on electronic B-stock (receipt required)
2 years on source units	

- **What is Covered**

This warranty applies only to Rockford Fosgate products sold to consumers by Authorized Rockford Fosgate Dealers in the United States of America or its possessions. Product purchased by consumers from an Authorized Rockford Fosgate Dealer in another country are covered only by that country's Distributor and not by Rockford Corporation.

- **Who is Covered**

This warranty covers only the original purchaser of Rockford product purchased from an Authorized Rockford Fosgate Dealer in the United States. In order to receive service, the purchaser must provide Rockford with a copy of the receipt stating the customer name, dealer name, product purchased and date of purchase.

- **Products found to be defective** during the warranty period will be repaired or replaced (with a product deemed to be equivalent) at Rockford's discretion.

- **What is Not Covered**

1. Damage caused by accident, abuse, improper operations, water, theft
2. Any cost or expense related to the removal or reinstallation of product
3. Service performed by anyone other than Rockford or an Authorized Rockford Fosgate Service Center
4. Any product which has had the serial number defaced, altered, or removed
5. Subsequent damage to other components
6. Any product purchased outside the U.S.
7. Any product not purchased from an Authorized Rockford Fosgate Dealer

- **Limit on Implied Warranties**

Any implied warranties including warranties of fitness for use and merchantability are limited in duration to the period of the express warranty set forth above. Some states do not allow limitations on the length of an implied warranty, so this limitation may not apply. No person is authorized to assume for Rockford Fosgate any other liability in connection with the sale of the product.

- **How to Obtain Service**

Please call 1-800-669-9899 for Rockford Customer Service. You must obtain an RA# (Return Authorization number) to return any product to Rockford Fosgate. You are responsible for shipment of product to Rockford.

Ship to: **Electronics**
Rockford Corporation
Warranty Repair Department
2055 E. 5th Street
Tempe, AZ 85281
RA#: _____

Ship to: **Speakers**
Rockford Acoustic Design
(Receiving-speakers)
609 Myrtle N.W.
Grand Rapids, MI 49504
RA#: _____



LEA DETENIDAMENTE LAS SIGUIENTES INSTRUCCIONES DE INSTALACIÓN DEL PRODUCTO.

INTRODUCCIÓN

Los woofers Punch de doble bobina son drivers diseñados primordialmente para utilizar en cajas cerradas pequeñas. El diseño de doble bobina permite que las cargas de baja impedancia sean configuradas para optimizar las prestaciones de los amplificadores Punch Power 50.1 y 50.2 Utilizando los últimos materiales y técnicas de construcción, somos capaces de ofrecer un altavoz con una respuesta óptima a baja frecuencia, requiriendo un espacio mínimo para su funcionamiento.

TERMINALES DE ENTRADA

Los terminales positivo y negativo de entrada están ubicados uno en cada extremo de la carcasa. Este montaje separado previene de posibles cortocircuitos de la señal a altos niveles de volumen. El terminal positivo está marcado con un punto en la carcasa. Un punto rojo indica que la impedancia del altavoz es de 8 ohmios, y un punto violeta que es de 4 ohmios.

CALCULO DEL VOLUMEN

Para calcular el volumen sólo se han de medir las dimensiones en centímetros y aplicar la fórmula:

$$\text{Volumen de la caja} = \frac{\text{Alto} \times \text{Ancho} \times \text{Profundidad}}{1000}$$

(en litros)

Si dos caras opuestas son de diferente tamaño, súmelas y divida el total por dos para obtener el promedio. Usando esta técnica se ahorrara el cálculo por secciones. El espesor del material con que está construida la caja reduce el volumen interno, de manera que ha de restarse de las dimensiones exteriores para determinar el volumen interior. La cantidad de aire que ocupa cada modelo viene especificado en la hoja de características y también debe sustraerse para obtener el volumen neto interior.

VEUILLEZ LIRE LES INSTRUCTIONS SUIVANTES POUR L'INSTALLATION DE CE PRODUIT.

INTRODUCTION

Les woofers Punch Double bobine sont des haut-parleurs de basses fréquences conçus à l'origine pour jouer dans des petits caissons. La conception à double bobine permet des charges de basses impédances destinées à optimiser les performances des amplis Punch Power 50.1 et 50.2. Grâce à l'utilisation de matériaux dernier cri et des plus récentes techniques de fabrication, nous pouvons vous offrir un haut-parleur avec une réponse en basses fréquences optimisée ne requérant qu'un minimum d'espace opérationnel.

FRANÇAIS

BORNIERS

Les bornes positives et négatives sont fixées de part et d'autre du saladier. Cette séparation permet d'empêcher les courts-circuits entre les fils lors des reproductions sonores élevées. **La borne positive est repérée par un petit point de couleur sur le saladier.** Un point rouge est utilisé pour les haut-parleurs de 8Ω , un point violet pour les haut-parleurs de 4Ω .

CALCUL DU VOLUME

On calcule le volume en mesurant la dimension de chaque côté et en utilisant la formule suivante:

$$\text{Volume du caisson (Litres)} = \frac{\text{Hauteur (cm)} \times \text{Longueur (cm)} \times \text{Largeur (cm)}}{1000}$$

Si les deux côtés qui se font face n'ont pas la même longueur, additionnez les et divisez le résultat par deux pour obtenir la moyenne des deux longueurs. Utilisez le nombre ainsi obtenu dans la formule pour déterminer le litrage. Cette méthode permet d'obtenir le volume du caisson sans devoir faire de calculs compliqués de section de volume. L'épaisseur du matériau dont est fait le caisson réduit le volume interne de celui-ci. Lorsqu'on mesure les côtés du caisson il ne faut donc pas oublier d'oter des mesures l'épaisseur du matériau. Le haut-parleur lui-même diminue le volume interne du caisson. Le volume d'air déplacé par chaque modèle de haut-parleur est repris dans les spécifications techniques et doit également être soustrait du volume total.

BITTE LESEN SIE DIESE GEBRAUCHSANLEITUNG ZUERST SORGFÄLTIG DURCH. DAS KANN SIE VOR FALSCEM EINSATZ, AUSFALLEN ODER SOGAR BESCHÄDIGUNG DES PRODUKTES ODER IHRES FAHRZEUGES SCHÜTZEN.

EINLEITUNG

Die Punch Doppel-Schwingspule Woofer sind Tieffrequenz-Woofer, die für kleine geschlossene Gehäuse konstruiert wurden. Die Doppel-Schwingspule erlaubt eine sehr niedrige Impedanz, genau richtig für die Optimierung der Leistung der neuen Punch Power 50.1 und 50.2 Endstufen. Unter der Verwendung neuester Materialien und konstruktionstechnikjen, können wir Ihnen einen Woofer für sehr tiefe Frequenzen, in sehr kleinen Gehäusen vorstellen.

ANSCHLUßTERMINALS

Die Anschlußterminals wurden auf jeder Seite des Lautsprecherkorbes positioniert um eventuelle Kurzschlüsse auch bei hoher Leistung auszuschließen (Das Positiv-Terminal ist durch eine Farbmarkierung gekennzeichnet). Eine rote Farbmarkierung befindet sich immer bei einem Lautsprecher mit einer Impedanz von 8 Ohm, eine violette Farbmarkierung zeichnet die Lautsprecher mit der Impedanz 4 Ohm.

VOLUMEN-BERECHNUNG

Zur Volumen-Berechnung benötigen sie die genauen Maße und Dimensionen in Zentimetern.

Gehäuse- Volumen = (Kubik Liter)	Höhe (cm) x Breite (cm) x Tiefe (cm) <hr/> 1000
--	--

Sollten zwei gegenüberliegende Seiten ungleich lang sein, so können sie die Maße zusammen rechnen und durch zwei dividieren um den Durchschnitt zu erhalten. Dies macht Ihnen die Berechnung leichter und Sie müssen das Gehäuse nicht in Sektionen berechnen, die Sie danach wieder mühselig zusammen zählen müssen. Die Materialstärke beeinflusst natürlich auch das Innen-Volumen, so muss für eine präzise Berechnung die Materialstärke von Außen-Volumen abgezogen werden. Der Lautsprecher verringert ebenfalls das Innen-Volumen, auch er sollte natürlich heraus gerechnet werden. Jedes Lautsprecher-Volumen ist unter "Specifications" genau aufgelistet.

LEGGERE CON ATTENZIONE LE SEGUENTI ISTRUZIONI PRIMA DELL'INSTALLAZIONE DEL PRODOTTO.

INTRODUZIONE

I woofer Punch a doppia bobina sono altoparlanti a bassa frequenza progettati soprattutto per l'impiego in cassa chiusa di limitato volume. Il progetto a doppia bobina consente la configurazione di carichi a bassa impedenza per ottimizzare le prestazioni degli amplificatori Punch Power 50.1 e 50.2. Impiegando i materiali e le tecniche di costruzione piú avanzati, siamo in grado di offrirvi un altoparlante che ottimizza la risposta a bassa frequenza richiedendo un minimo spazio operativo.

CONNESSIONI DI INGRESSO

I connettori di ingresso positivi e negativi sono montati sul cestello in posizioni speculari. Il montaggio separato impedisce al segnale musicale di cortocircuitarsi ad altissimi livelli di volume. (Il terminale di ingresso é indicato da una marcatura colorata sul cestello.) Un contrassegno rosso indica che l'impedenza dell'altoparlante é 8 ohm, il contrassegno viola é impiegato per i 4 ohm.

CALCOLO DEL VOLUME

Calcolare il volume é essenzialmente solo un problema di misurazione delle dimensioni in centimetri della cassa e di applicazione della formula:

Volume della cassa = (litri)	$\frac{\text{Alteza x Larghezza x Profonditá}}{1000}$
--	---

Se due pareti parallele sono di dimensioni diverse (prisma), semplicemente sommatele e dividete il risultato per due. Impiegando il risultato ottenuto potete calcolare il volume senza dividere la cassa i sezioni. Lo spessore del legno riduce il volume interno, per cui é necessario sottrarlo dalle dimensioni esterne. Anche il volume dell'altoparlante stesso riduce il volume della cassa e deve essere sottratto. Il volume che ciascun altoparlante contribuisce a togliere dalla cassa é indicato nelle tabelle con le specifiche.

ITALIANO

MADE IN THE USA

This product is designed, developed and assembled in the USA by a dedicated group of American workers. The majority of the components used in the construction of this product are produced by American companies. However, due to the global nature of their manufacturing facilities and the loudspeaker parts industry in general, some parts may be manufactured in other countries.

Rockford Fosgate

Rockford Corporation
546 South Rockford Drive
Tempe, Arizona 85281 U.S.A.
In U.S.A., (602) 967-3565
In Europe, Fax (49) 4207-801250
In Japan, Fax (81) 559-79-1265